

# Product datasheet

Specifications



variable speed drive ATV610. 75 kW/100 HP. 380...460 V. IP20

ATV610D75N4

**Price: 106,004.53 ZAR**

## Main

Range Of Product	Easy Altivar 610
Product Or Component Type	Variable speed drive
Product Specific Application	Fan, pump, compressor, conveyor
Device Short Name	ATV610
Variant	Standard version
Product Destination	Asynchronous motors Synchronous motors
Mounting Mode	Cabinet mount
Emc Filter	Integrated conforming to IEC 61800-3 category C3 with 50 m
Ip Degree Of Protection	IP20
Type Of Cooling	Forced convection
Supply Frequency	50...60 Hz +/-5 %
Network Number Of Phases	3 phases
[Us] Rated Supply Voltage	380...460 V - 15...10 %
Motor Power Kw	75 kW for normal duty 55 kW for heavy duty
Motor Power Hp	100 hp for normal duty 75 hp for heavy duty
Line Current	147.9 A at 380 V (normal duty) 130.2 A at 460 V (normal duty) 115.8 A at 380 V (heavy duty) 101.7 A at 460 V (heavy duty)
Prospective Line Isc	22 kA
Apparent Power	103.7 kVA at 460 V (normal duty) 81.0 kVA at 460 V (heavy duty)
Continuous Output Current	145 A at 2.5 kHz for normal duty 106 A at 2.5 kHz for heavy duty
Maximum Transient Current	160 A during 60 s (normal duty) 159 A during 60 s (heavy duty)
Asynchronous Motor Control Profile	Constant torque standard Optimized torque mode Variable torque standard
Output Frequency	0.1...500 Hz
Nominal Switching Frequency	2.5 kHz
Switching Frequency	1...8 kHz adjustable
Number Of Preset Speeds	16 preset speeds

Excluding VAT and subject to change. Please check with your local distributor through "Where to buy"

<b>Communication Port Protocol</b>	Modbus serial
<b>Option Card</b>	Slot A: communication card, Profibus DP V1 Slot A: digital or analog I/O extension card Slot A: relay output card

## Complementary

<b>Output Voltage</b>	<= power supply voltage
<b>Motor Slip Compensation</b>	Automatic whatever the load Can be suppressed Adjustable Not available in permanent magnet motor law
<b>Acceleration And Deceleration Ramps</b>	S, U or customized Linear adjustable separately from 0.01 to 9000 s
<b>Braking To Standstill</b>	By DC injection
<b>Protection Type</b>	Thermal protection: motor Motor phase break: motor Thermal protection: drive Overheating: drive Overcurrent between output phases and earth: drive Overload of output voltage: drive Short-circuit protection: drive Motor phase break: drive Overvoltages on the DC bus: drive Line supply overvoltage: drive Line supply undervoltage: drive Line supply phase loss: drive Overspeed: drive Break on the control circuit: drive
<b>Frequency Resolution</b>	Display unit: 0.1 Hz Analog input: 0.012/50 Hz
<b>Electrical Connection</b>	Control, screw terminal: 0.5...1.5 mm <sup>2</sup> Line side, screw terminal: 95...120 mm <sup>2</sup> Motor, screw terminal: 95...120 mm <sup>2</sup>
<b>Connector Type</b>	1 RJ45 (on the remote graphic terminal) for Modbus serial
<b>Physical Interface</b>	2-wire RS 485 for Modbus serial
<b>Transmission Frame</b>	RTU for Modbus serial
<b>Transmission Rate</b>	4.8, 9.6, 19.2, 38.4 kbit/s for Modbus serial
<b>Type Of Polarization</b>	No impedance for Modbus serial
<b>Number Of Addresses</b>	1...247 for Modbus serial
<b>Method Of Access</b>	Slave
<b>Supply</b>	External supply for digital inputs: 24 V DC (19...30 V), <1.25 mA, protection type: overload and short-circuit protection Internal supply for reference potentiometer (1 to 10 kOhm): 10.5 V DC +/- 5 %, <10 mA, protection type: overload and short-circuit protection
<b>Local Signalling</b>	2 LEDs for local diagnostic 1 LED (yellow) for embedded communication status 2 LEDs (dual colour) for communication module status 1 LED (red) for presence of voltage
<b>Width</b>	290 mm
<b>Height</b>	762 mm 922 mm with EMC plate
<b>Depth</b>	323 mm
<b>Net Weight</b>	53 kg
<b>Analogue Input Number</b>	3

<b>Analogue Input Type</b>	AI1, AI2, AI3 software-configurable voltage: 0...10 V DC, impedance: 30 kOhm, resolution 12 bits AI1, AI2, AI3 software-configurable current: 0...20 mA, impedance: 250 Ohm, resolution 12 bits AI2, AI3 software-configurable temperature probe or water level sensor
<b>Discrete Input Number</b>	6
<b>Discrete Input Type</b>	DI1...DI6 programmable as logic input, 24 V DC ( $\leq 30$ V), impedance: 3.5 kOhm DI5, DI6 programmable as pulse input: 0...30 kHz, 24 V DC ( $\leq 30$ V)
<b>Input Compatibility</b>	DI1...DI6: logic input level 1 PLC conforming to IEC 61131-2 DI5, DI6: pulse input level 1 PLC conforming to IEC 65A-68
<b>Discrete Input Logic</b>	Positive logic (source): DI1...DI6 configurable logic input, $< 5$ V (state 0), $> 11$ V (state 1) Negative logic (sink): DI1...DI6 configurable logic input, $> 16$ V (state 0), $< 10$ V (state 1) Positive logic (source): DI5, DI6 configurable pulse input, $< 0.6$ V (state 0), $> 2.5$ V (state 1)
<b>Analogue Output Number</b>	2
<b>Analogue Output Type</b>	Software-configurable current AQ1, AQ2: 0...20 mA, resolution 10 bits Software-configurable voltage AQ1, AQ2: 0...10 V DC impedance 470 Ohm, resolution 10 bits
<b>Sampling Duration</b>	5 ms $\pm$ 0.1 ms (AI1, AI2, AI3) - analog input 2 ms $\pm$ 0.5 ms (DI1...DI6)configurable - discrete input 5 ms $\pm$ 1 ms (DI5, DI6)configurable - pulse input 10 ms $\pm$ 1 ms (AQ1, AQ2) - analog output
<b>Accuracy</b>	$\pm$ 0.6 % AI1, AI2, AI3 for a temperature variation 60 °C analog input $\pm$ 1 % AQ1, AQ2 for a temperature variation 60 °C analog output
<b>Linearity Error</b>	AI1, AI2, AI3: $\pm$ 0.15 % of maximum value for analog input AQ1, AQ2: $\pm$ 0.2 % for analog output
<b>Relay Output Number</b>	3
<b>Relay Output Type</b>	Configurable relay logic R1: fault relay NO/NC electrical durability 100000 cycles Configurable relay logic R2: sequence relay NO electrical durability 100000 cycles Configurable relay logic R3: sequence relay NO electrical durability 100000 cycles
<b>Refresh Time</b>	Relay output (R1, R2, R3): 5 ms ( $\pm$ 0.5 ms)
<b>Minimum Switching Current</b>	Relay output R1, R2, R3: 5 mA at 24 V DC
<b>Maximum Switching Current</b>	Relay output R1, R2, R3 on resistive load, $\cos \phi = 1$ : 3 A at 250 V AC Relay output R1, R2, R3 on resistive load, $\cos \phi = 1$ : 3 A at 30 V DC Relay output R1, R2, R3 on inductive load, $\cos \phi = 0.4$ and L/R = 7 ms: 2 A at 250 V AC Relay output R1, R2, R3 on inductive load, $\cos \phi = 0.4$ and L/R = 7 ms: 2 A at 30 V DC
<b>Isolation</b>	Between power and control terminals
<b>Insulation Resistance</b>	$> 1$ MOhm 500 V DC for 1 minute to earth

## Environment

<b>Noise Level</b>	78 dB conforming to 86/188/EEC
<b>Power Dissipation In W</b>	1460 W(forced convection) at 380 V, switching frequency 2.5 kHz 177 W(natural convection) at 380 V, switching frequency 2.5 kHz
<b>Volume Of Cooling Air</b>	295 m <sup>3</sup> /h
<b>Operating Position</b>	Vertical $\pm$ 10 degree
<b>Electromagnetic Compatibility</b>	Electrostatic discharge immunity test level 3 conforming to IEC 61000-4-2 Radiated radio-frequency electromagnetic field immunity test level 3 conforming to IEC 61000-4-3 Electrical fast transient/burst immunity test level 4 conforming to IEC 61000-4-4 1.2/50 $\mu$ s - 8/20 $\mu$ s surge immunity test level 3 conforming to IEC 61000-4-5 Conducted radio-frequency immunity test level 3 conforming to IEC 61000-4-6
<b>Pollution Degree</b>	2 conforming to IEC 61800-5-1

<b>Vibration Resistance</b>	1.5 mm peak to peak (f= 2...13 Hz) conforming to IEC 60068-2-6 1 gn (f= 13...200 Hz) conforming to IEC 60068-2-6
<b>Shock Resistance</b>	15 gn for 11 ms conforming to IEC 60068-2-27
<b>Relative Humidity</b>	5...95 % without condensation conforming to IEC 60068-2-3
<b>Ambient Air Temperature For Operation</b>	-15...45 °C (without derating) 45...60 °C (with derating factor)
<b>Ambient Air Temperature For Storage</b>	-40...70 °C
<b>Operating Altitude</b>	<= 1000 m without derating 1000...4800 m with current derating 1 % per 100 m
<b>Environmental Characteristic</b>	Chemical pollution resistance class 3C3 conforming to IEC 60721-3-3 Dust pollution resistance class 3S3 conforming to IEC 60721-3-3
<b>Standards</b>	IEC 61800-3 Environment 2 category C3 IEC 61800-3 IEC 61800-5-1 IEC 60721-3
<b>Marking</b>	CE

## Packing Units

<b>Unit Type Of Package 1</b>	PCE
<b>Number Of Units In Package 1</b>	1
<b>Package 1 Height</b>	46.500 cm
<b>Package 1 Width</b>	58.000 cm
<b>Package 1 Length</b>	93.500 cm
<b>Package 1 Weight</b>	70.500 kg

## Sustainability

**Green Premium™ label** is Schneider Electric's commitment to delivering products with best-in-class environmental performance. Green Premium promises compliance with the latest regulations, transparency on environmental impacts, as well as circular and low-CO<sub>2</sub> products.

**Guide to assessing product sustainability** is a white paper that clarifies global eco-label standards and how to interpret environmental declarations.

[Learn more about Green Premium >](#)

[Guide to assess a product's sustainability >](#)



Transparency RoHS/REACH

## Resource performance

Upgradeable Through Digital Modules  
And Upgraded Components

## Well-being performance

Mercury Free

Rohs Exemption Information Yes

## Certifications & Standards

**Reach Regulation** [REACH Declaration](#)

**Eu Rohs Directive** Pro-active compliance (Product out of EU RoHS legal scope)

**China Rohs Regulation** [China RoHS declaration](#)

**Environmental Disclosure** [Product Environmental Profile](#)

**Weee** The product must be disposed on European Union markets following specific waste collection and never end up in rubbish bins

**Circularity Profile** [End of Life Information](#)

Dimensions Drawings

Dimensions

IP20 Drives

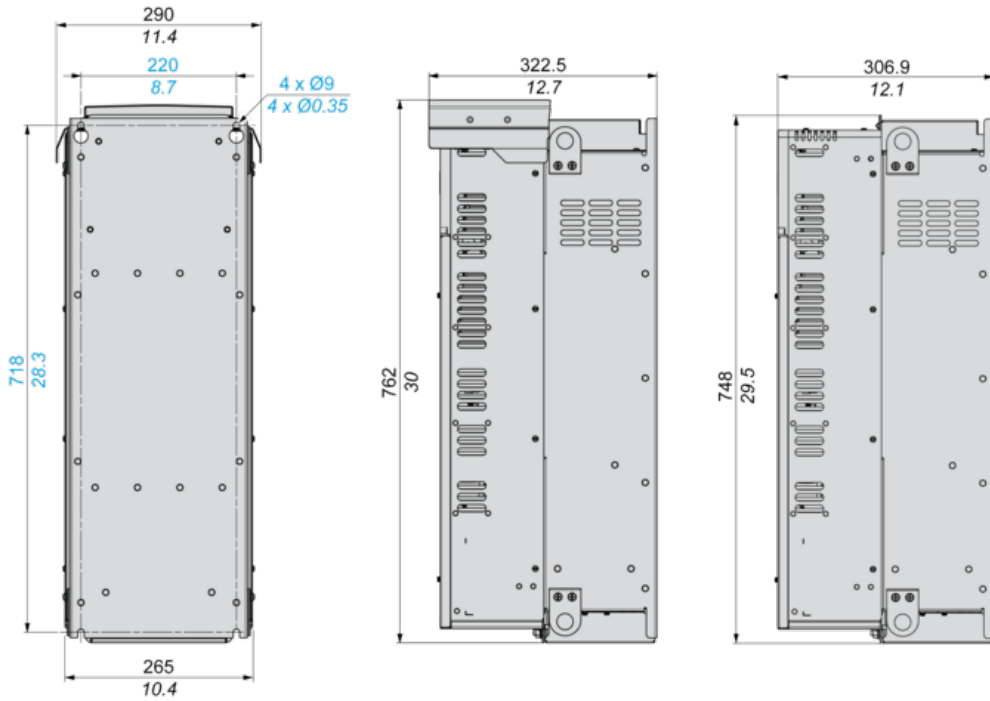

Drawings from left to right: rear view, right side view with top cover, right side view without top cover.

IP20 Drives With EMC Plate

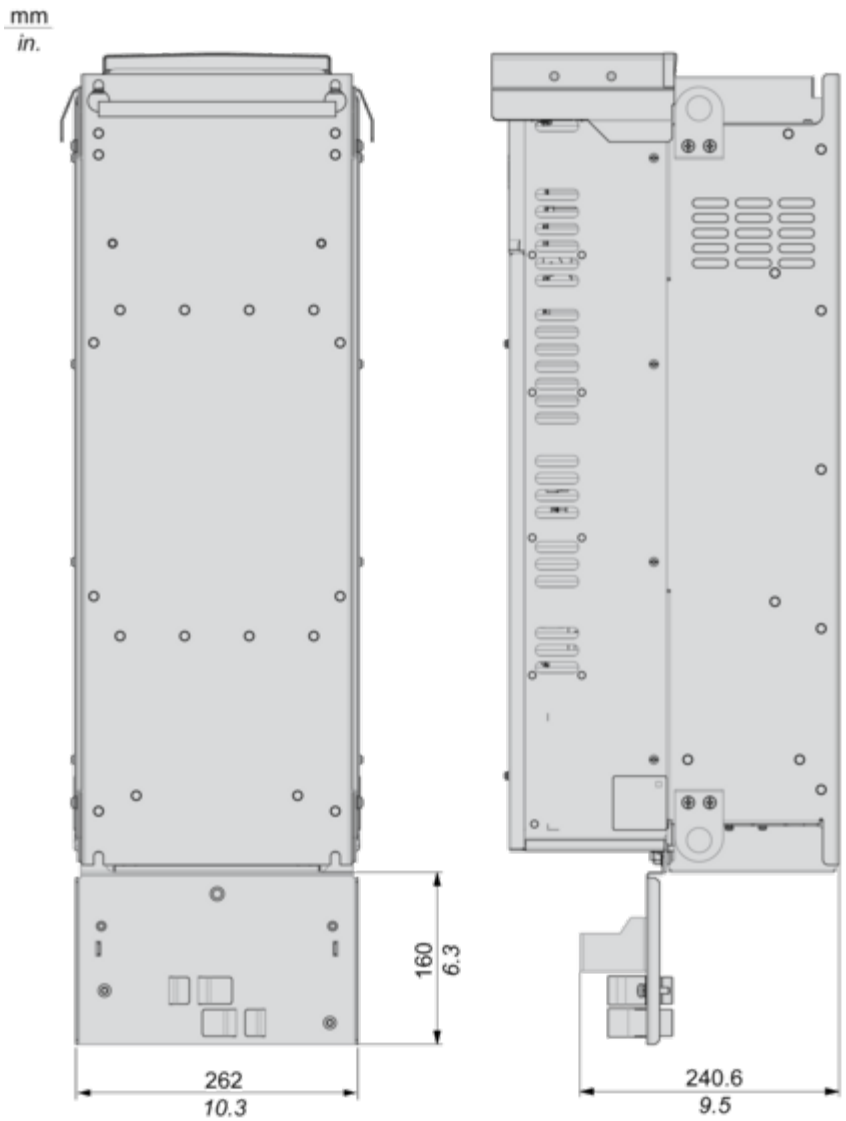

Drawings from left to right: rear view, right side view with top cover.

Mounting and Clearance

Clearances

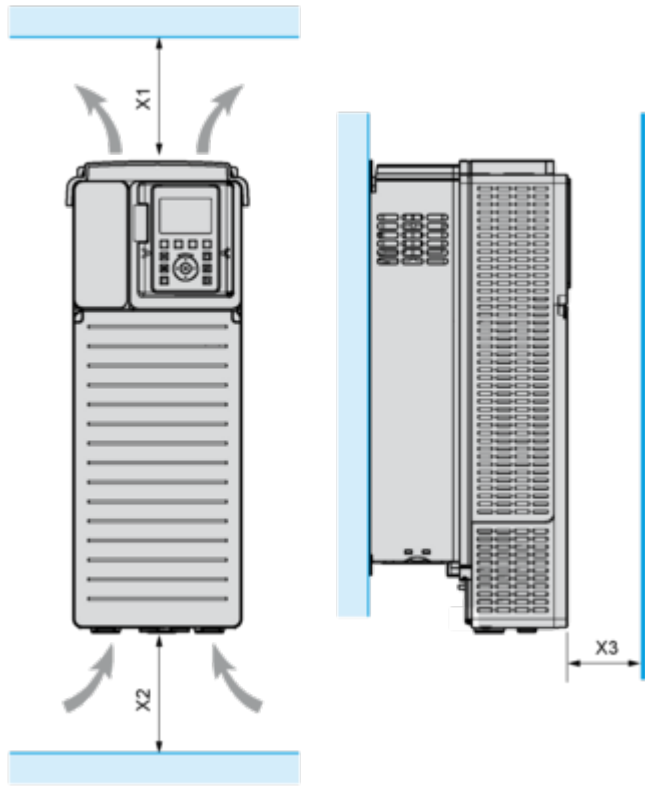

X1	X2	X3
≥ 100 mm (3.94 in.)	≥ 100 mm (3.94 in.)	≥ 10 mm (0.39 in.)

- Mount the device in a vertical position ( $\pm 10^\circ$ ). This is required for cooling the device.
- Do not mount the device close to heat sources.
- Leave sufficient free space so that the air required for cooling purposes can circulate from the bottom to the top of the drive.

**Mounting Types**

---

**Mounting Type A: Individual IP21**

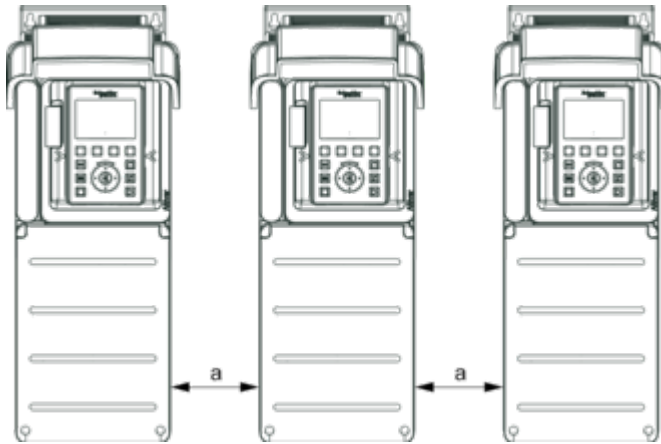

$a \geq 110 \text{ mm (4.33 in.)}$

**Mounting Type B: Side by Side IP20 (Possible, 2 Drives Only)**

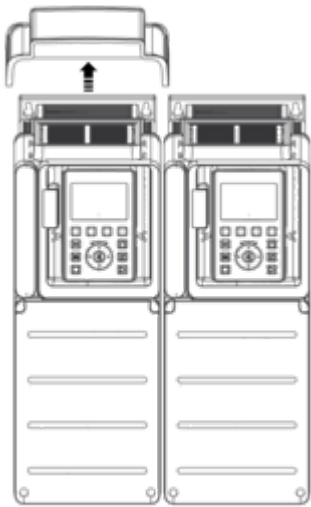

**Mounting Type C: Individual IP20**

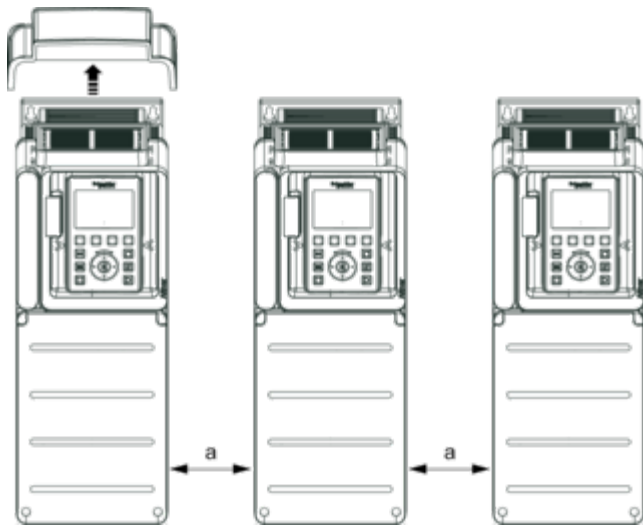

$a \geq 110 \text{ mm (4.33 in.)}$

Connections and Schema

Single or Three-phase Power Supply - Diagram With Line Contactor

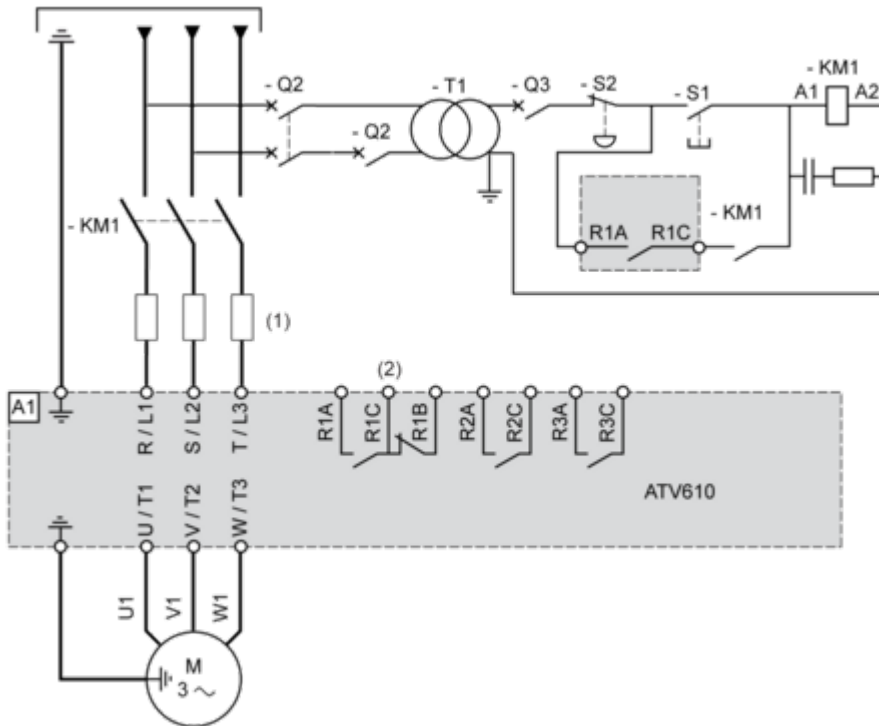

- (1) Line chokes
- (2) See control block wiring diagram
- A1 : Drive
- KM1 : Line Contactor
- Q2, Q3 : Circuit breakers
- S1, S2 : Pushbuttons
- T1 : Transformer for control part

Control Block Wiring Diagram

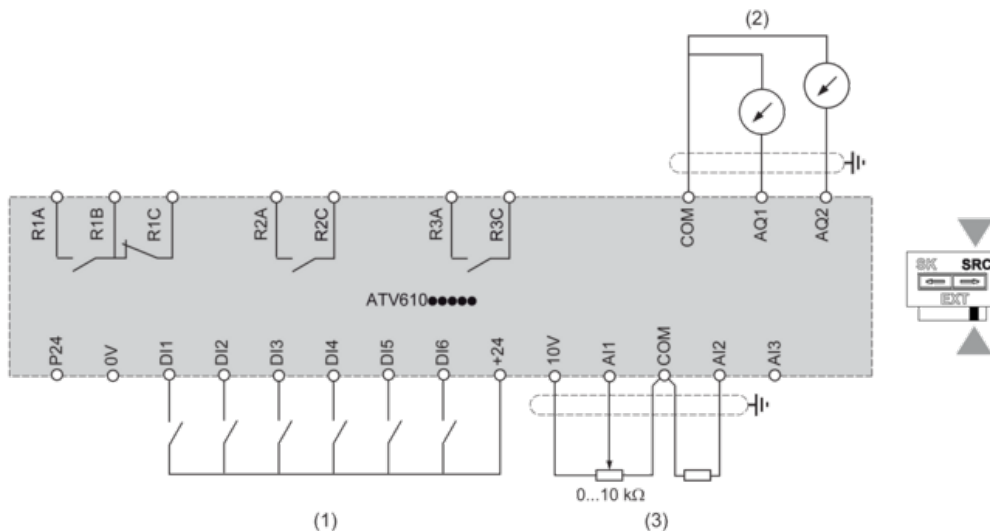

- (1) Digital Input
- (2) Analog Output
- (3) Analog Input
- R1A, R1B, R1C : Fault relay output
- R2A, R2C : Sequence relay output
- R3A, R3C : Sequence relay output

Sensor Connection

It is possible to connect either 1 or 3 sensors on terminals AI2 or AI3.

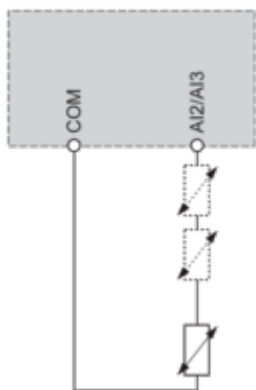

Performance Curves

Derating Curves

---

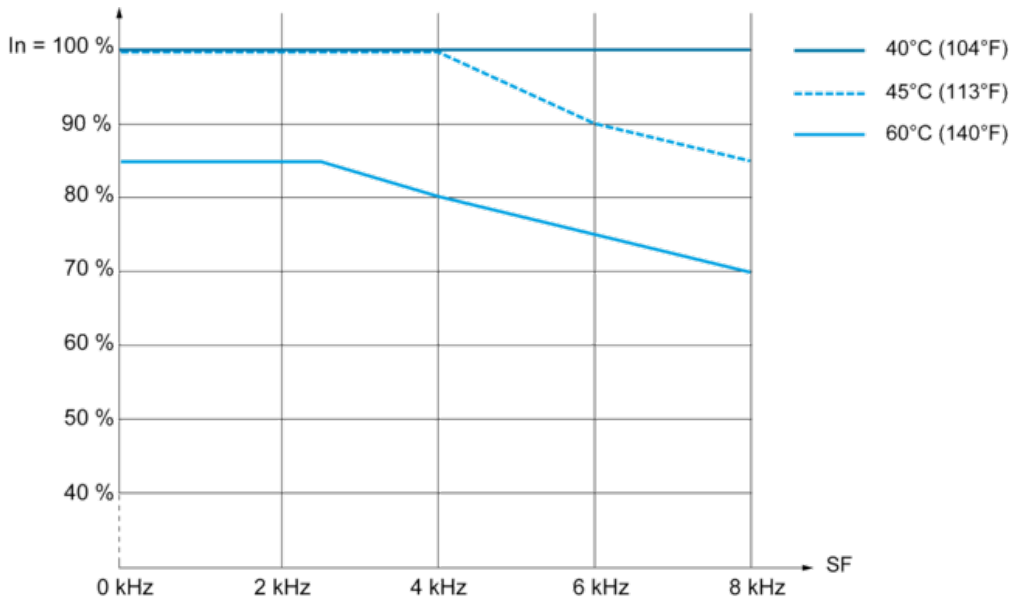

In : Nominal Drive Current  
SF : Switching Frequency