

Product datasheet

Specifications



variable speed drive ATV610. 1.5 kW/2HP. 380...460 V. IP20

ATV610U15N4

Price: 13,123.55 ZAR

Main

| | |
|------------------------------------|--|
| Range Of Product | Easy Altivar 610 |
| Product Or Component Type | Variable speed drive |
| Product Specific Application | Fan, pump, compressor, conveyor |
| Device Short Name | ATV610 |
| Variant | Standard version |
| Product Destination | Asynchronous motors Synchronous motors |
| Mounting Mode | Cabinet mount |
| Emc Filter | Integrated conforming to IEC 61800-3 category C3 with 50 m |
| Ip Degree Of Protection | IP20 |
| Type Of Cooling | Forced convection |
| Supply Frequency | 50...60 Hz +/-5 % |
| Network Number Of Phases | 3 phases |
| [Us] Rated Supply Voltage | 380...460 V - 15...10 % |
| Motor Power Kw | 1.5 kW for normal duty 0.75 kW for heavy duty |
| Motor Power Hp | 2 hp for normal duty 1 hp for heavy duty |
| Line Current | 5.7 A at 380 V (normal duty) 4.8 A at 460 V (normal duty) 3.1 A at 380 V (heavy duty) 2.6 A at 460 V (heavy duty) |
| Prospective Line Isc | 5 kA |
| Apparent Power | 3.8 kVA at 460 V (normal duty) 2.1 kVA at 460 V (heavy duty) |
| Continuous Output Current | 4 A at 4 kHz for normal duty 2.2 A at 4 kHz for heavy duty |
| Maximum Transient Current | 4.4 A during 60 s (normal duty) 3.3 A during 60 s (heavy duty) |
| Asynchronous Motor Control Profile | Optimized torque mode Constant torque standard Variable torque standard |
| Output Frequency | 0.1...500 Hz |
| Nominal Switching Frequency | 4 kHz |
| Switching Frequency | 2...12 kHz adjustable |
| Number Of Preset Speeds | 16 preset speeds |

Excluding VAT and subject to change. Please check with your local distributor through "Where to buy"

| | |
|------------------------------------|---|
| Communication Port Protocol | Modbus serial |
| Option Card | Slot A: communication card, Profibus DP V1 Slot A: digital or analog I/O extension card Slot A: relay output card |

Complementary

| | |
|--|--|
| Output Voltage | <= power supply voltage |
| Motor Slip Compensation | Adjustable Automatic whatever the load Not available in permanent magnet motor law Can be suppressed |
| Acceleration And Deceleration Ramps | S, U or customized Linear adjustable separately from 0.01 to 9000 s |
| Braking To Standstill | By DC injection |
| Protection Type | Thermal protection: motor Motor phase break: motor Thermal protection: drive Overheating: drive Overcurrent between output phases and earth: drive Overload of output voltage: drive Short-circuit protection: drive Motor phase break: drive Overvoltages on the DC bus: drive Line supply overvoltage: drive Line supply undervoltage: drive Line supply phase loss: drive Overspeed: drive Break on the control circuit: drive |
| Frequency Resolution | Display unit: 0.1 Hz Analog input: 0.012/50 Hz |
| Electrical Connection | Control, screw terminal: 0.5...1.5 mm ² Line side, screw terminal: 2.5...16 mm ² Motor, screw terminal: 2.5...16 mm ² |
| Connector Type | 1 RJ45 (on the remote graphic terminal) for Modbus serial |
| Physical Interface | 2-wire RS 485 for Modbus serial |
| Transmission Frame | RTU for Modbus serial |
| Transmission Rate | 4.8, 9.6, 19.2, 38.4 kbit/s for Modbus serial |
| Type Of Polarization | No impedance for Modbus serial |
| Number Of Addresses | 1...247 for Modbus serial |
| Method Of Access | Slave |
| Supply | External supply for digital inputs: 24 V DC (19...30 V), <1.25 mA, protection type: overload and short-circuit protection Internal supply for reference potentiometer (1 to 10 kOhm): 10.5 V DC +/- 5 %, <10 mA, protection type: overload and short-circuit protection |
| Local Signalling | 2 LEDs for local diagnostic 1 LED (yellow) for embedded communication status 2 LEDs (dual colour) for communication module status 1 LED (red) for presence of voltage |
| Width | 145 mm |
| Height | 297 mm 350 mm with EMC plate |
| Depth | 203 mm |
| Net Weight | 3.135 kg |
| Analogue Input Number | 3 |

| | |
|----------------------------------|--|
| Analogue Input Type | AI1, AI2, AI3 software-configurable voltage: 0...10 V DC, impedance: 30 kOhm, resolution 12 bits AI1, AI2, AI3 software-configurable current: 0...20 mA, impedance: 250 Ohm, resolution 12 bits AI2, AI3 software-configurable temperature probe or water level sensor |
| Discrete Input Number | 6 |
| Discrete Input Type | DI1...DI6 programmable as logic input, 24 V DC (≤ 30 V), impedance: 3.5 kOhm DI5, DI6 programmable as pulse input: 0...30 kHz, 24 V DC (≤ 30 V) |
| Input Compatibility | DI1...DI6: logic input level 1 PLC conforming to IEC 61131-2 DI5, DI6: pulse input level 1 PLC conforming to IEC 65A-68 |
| Discrete Input Logic | Positive logic (source): DI1...DI6 configurable logic input, < 5 V (state 0), > 11 V (state 1) Negative logic (sink): DI1...DI6 configurable logic input, > 16 V (state 0), < 10 V (state 1) Positive logic (source): DI5, DI6 configurable pulse input, < 0.6 V (state 0), > 2.5 V (state 1) |
| Analogue Output Number | 2 |
| Analogue Output Type | Software-configurable current AQ1, AQ2: 0...20 mA, resolution 10 bits Software-configurable voltage AQ1, AQ2: 0...10 V DC impedance 470 Ohm, resolution 10 bits |
| Sampling Duration | 5 ms \pm 0.1 ms (AI1, AI2, AI3) - analog input 2 ms \pm 0.5 ms (DI1...DI6)configurable - discrete input 5 ms \pm 1 ms (DI5, DI6)configurable - pulse input 10 ms \pm 1 ms (AQ1, AQ2) - analog output |
| Accuracy | \pm 0.6 % AI1, AI2, AI3 for a temperature variation 60 °C analog input \pm 1 % AQ1, AQ2 for a temperature variation 60 °C analog output |
| Linearity Error | AI1, AI2, AI3: \pm 0.15 % of maximum value for analog input AQ1, AQ2: \pm 0.2 % for analog output |
| Relay Output Number | 3 |
| Relay Output Type | Configurable relay logic R1: fault relay NO/NC electrical durability 100000 cycles Configurable relay logic R2: sequence relay NO electrical durability 100000 cycles Configurable relay logic R3: sequence relay NO electrical durability 100000 cycles |
| Refresh Time | Relay output (R1, R2, R3): 5 ms (\pm 0.5 ms) |
| Minimum Switching Current | Relay output R1, R2, R3: 5 mA at 24 V DC |
| Maximum Switching Current | Relay output R1, R2, R3 on resistive load, $\cos \phi = 1$: 3 A at 250 V AC Relay output R1, R2, R3 on resistive load, $\cos \phi = 1$: 3 A at 30 V DC Relay output R1, R2, R3 on inductive load, $\cos \phi = 0.4$ and L/R = 7 ms: 2 A at 250 V AC Relay output R1, R2, R3 on inductive load, $\cos \phi = 0.4$ and L/R = 7 ms: 2 A at 30 V DC |
| Isolation | Between power and control terminals |
| Insulation Resistance | > 1 MOhm 500 V DC for 1 minute to earth |

Environment

| | |
|--------------------------------------|--|
| Noise Level | 55 dB conforming to 86/188/EEC |
| Power Dissipation In W | 40 W(forced convection) at 380 V, switching frequency 4 kHz 25 W(natural convection) at 380 V, switching frequency 4 kHz |
| Operating Position | Vertical \pm 10 degree |
| Electromagnetic Compatibility | Electrostatic discharge immunity test level 3 conforming to IEC 61000-4-2 Radiated radio-frequency electromagnetic field immunity test level 3 conforming to IEC 61000-4-3 Electrical fast transient/burst immunity test level 4 conforming to IEC 61000-4-4 1.2/50 μ s - 8/20 μ s surge immunity test level 3 conforming to IEC 61000-4-5 Conducted radio-frequency immunity test level 3 conforming to IEC 61000-4-6 |
| Pollution Degree | 2 conforming to IEC 61800-5-1 |
| Vibration Resistance | 1.5 mm peak to peak ($f = 2...13$ Hz) conforming to IEC 60068-2-6 1 gn ($f = 13...200$ Hz) conforming to IEC 60068-2-6 |

| | |
|--|--|
| Shock Resistance | 15 gn for 11 ms conforming to IEC 60068-2-27 |
| Relative Humidity | 5...95 % without condensation conforming to IEC 60068-2-3 |
| Ambient Air Temperature For Operation | -15...45 °C (without derating) 45...60 °C (with derating factor) |
| Operating Altitude | <= 1000 m without derating 1000...4800 m with current derating 1 % per 100 m |
| Environmental Characteristic | Chemical pollution resistance class 3C3 conforming to IEC 60721-3-3 Dust pollution resistance class 3S3 conforming to IEC 60721-3-3 |
| Standards | IEC 61800-3 Environment 2 category C3 IEC 61800-3 IEC 61800-5-1 IEC 60721-3 |
| Marking | CE |

Packing Units

| | |
|-------------------------------------|---------|
| Unit Type Of Package 1 | PCE |
| Number Of Units In Package 1 | 1 |
| Package 1 Height | 19.6 cm |
| Package 1 Width | 12.8 cm |
| Package 1 Length | 28.0 cm |
| Package 1 Weight | 5.7 kg |

Sustainability

Green Premium™ label is Schneider Electric's commitment to delivering products with best-in-class environmental performance. Green Premium promises compliance with the latest regulations, transparency on environmental impacts, as well as circular and low-CO₂ products.

Guide to assessing product sustainability is a white paper that clarifies global eco-label standards and how to interpret environmental declarations.

[Learn more about Green Premium >](#)

[Guide to assess a product's sustainability >](#)



Transparency RoHS/REACH

Resource performance

✓ Upgradeable Through Digital Modules
And Upgraded Components

Well-being performance

✓ Mercury Free

✓ Rohs Exemption Information Yes

Certifications & Standards

Reach Regulation [REACH Declaration](#)

Eu Rohs Directive Pro-active compliance (Product out of EU RoHS legal scope)

China Rohs Regulation [China RoHS declaration](#)

Environmental Disclosure [Product Environmental Profile](#)

Weee The product must be disposed on European Union markets following specific waste collection and never end up in rubbish bins

Circularity Profile [End of Life Information](#)

Dimensions Drawings

Dimensions

IP20 Drives

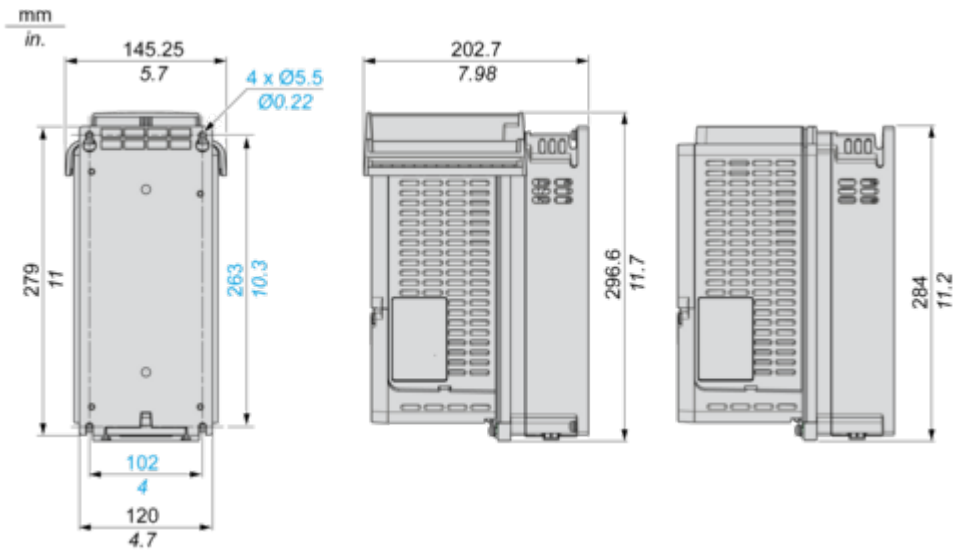

Drawings from left to right: rear view, right side view with top cover, right side view without top cover.

IP20 Drives With EMC Plate

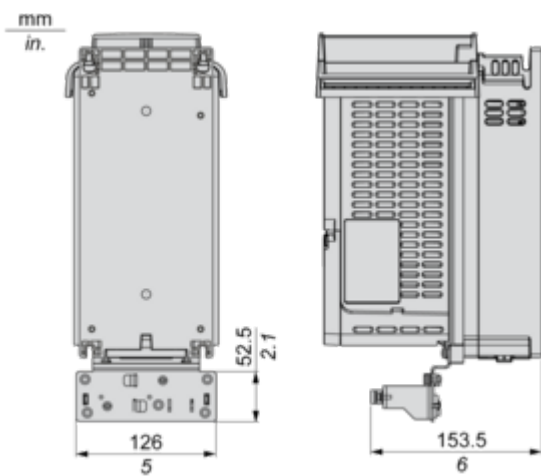

Drawings from left to right: rear view, right side view with top cover.

Mounting and Clearance

Clearances

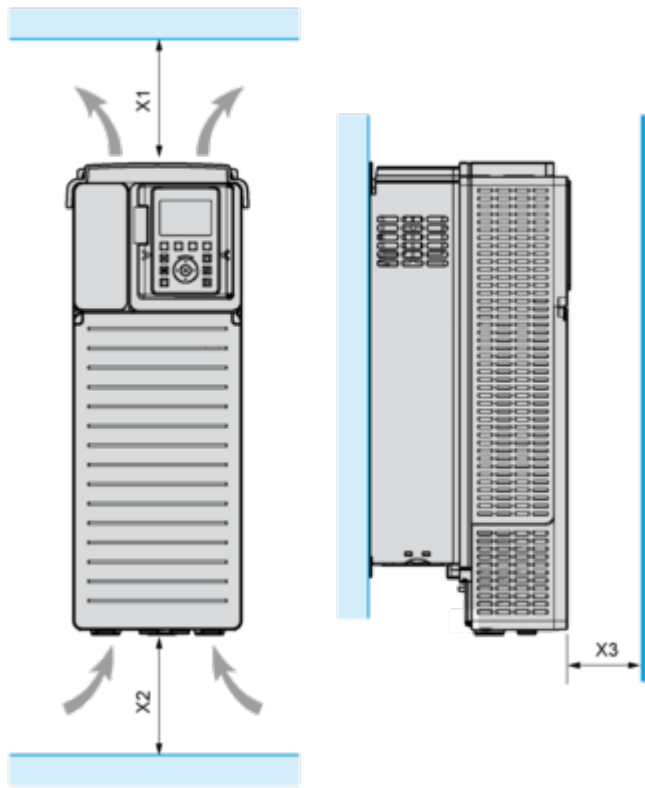

| X1 | X2 | X3 |
|---------------------|---------------------|--------------------|
| ≥ 100 mm (3.94 in.) | ≥ 100 mm (3.94 in.) | ≥ 10 mm (0.39 in.) |

- Mount the device in a vertical position ($\pm 10^\circ$). This is required for cooling the device.
- Do not mount the device close to heat sources.
- Leave sufficient free space so that the air required for cooling purposes can circulate from the bottom to the top of the drive.

Mounting Types

Mounting Type A: Individual IP21

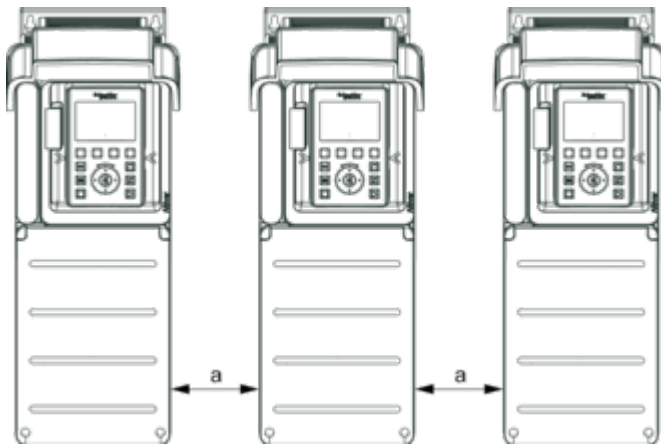

$a \geq 100 \text{ mm (3.94 in.)}$

Mounting Type B: Side by Side IP20

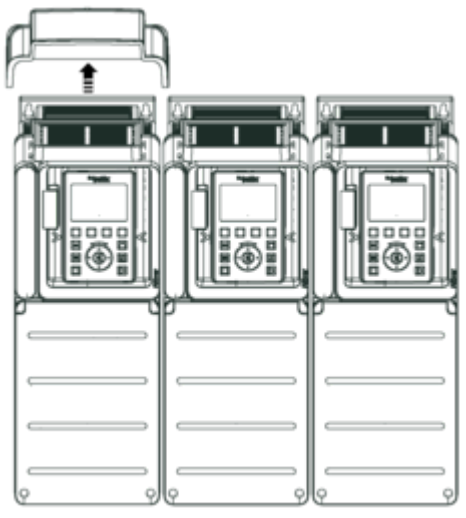

Connections and Schema

Single or Three-phase Power Supply - Diagram With Line Contactor

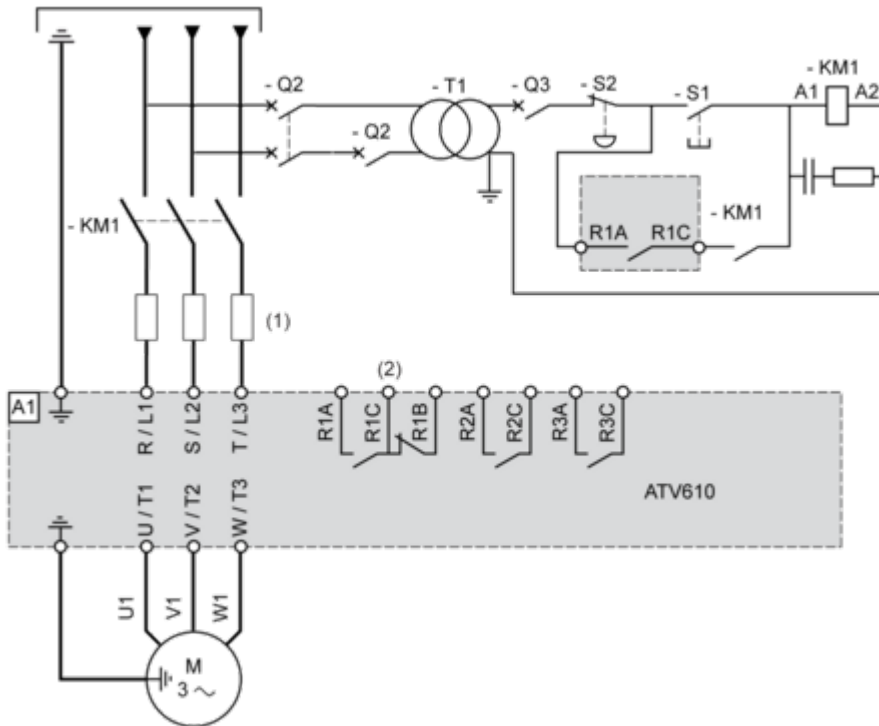

- (1) Line chokes
- (2) See control block wiring diagram
- A1 : Drive
- KM1 : Line Contactor
- Q2, Q3 : Circuit breakers
- S1, S2 : Pushbuttons
- T1 : Transformer for control part

Control Block Wiring Diagram

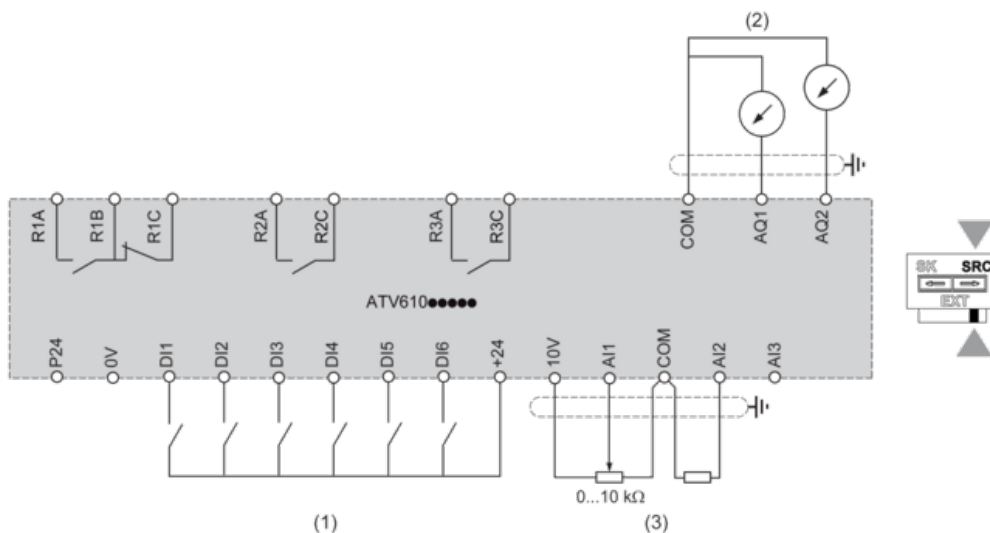

- (1) Digital Input
- (2) Analog Output
- (3) Analog Input
- R1A, R1B, R1C : Fault relay output
- R2A, R2C : Sequence relay output
- R3A, R3C : Sequence relay output

Sensor Connection

It is possible to connect either 1 or 3 sensors on terminals AI2 or AI3.

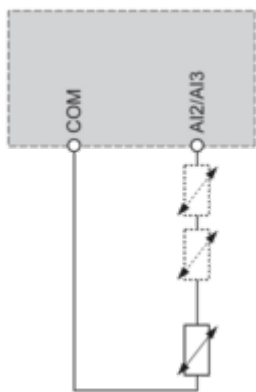

Performance Curves

Derating Curves

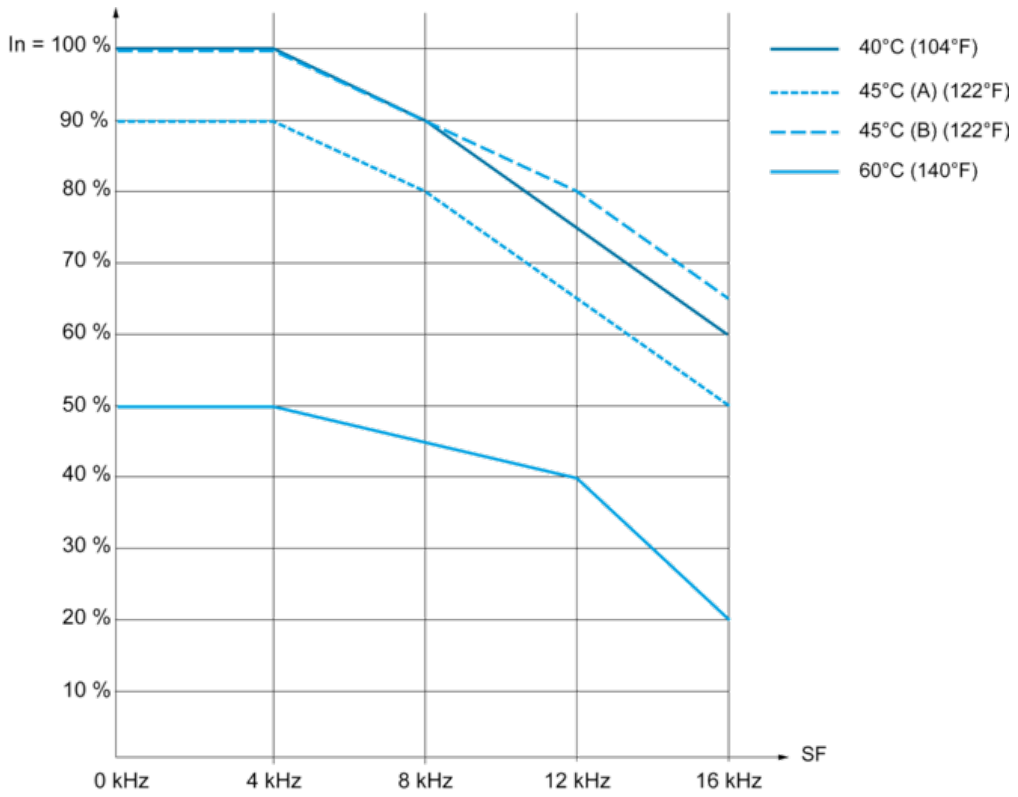

In : Nominal Drive Current
SF : Switching Frequency