

# Product datasheet

Specifications



Variable speed drive. Altivar Process ATV900. ATV950. 11 kW. 400/480 V. w braking unit/switch. IP55

ATV950D11N4E

**Price: 59,385.52 ZAR**

## Main

<b>Range Of Product</b>	Altivar Process ATV900
<b>Device Application</b>	Industrial application
<b>Product Or Component Type</b>	Variable speed drive
<b>Product Destination</b>	Synchronous motors Asynchronous motors
<b>Product Specific Application</b>	Process for industrial
<b>Variant</b>	With braking chopper With load break switch
<b>Network Number Of Phases</b>	3 phases
<b>Mounting Mode</b>	Wall mount
<b>Communication Port Protocol</b>	Modbus serial EtherNet/IP Modbus TCP
<b>[Us] Rated Supply Voltage</b>	380...480 V - 15...10 %
<b>Motor Power Kw</b>	11.0 kW for normal duty 7.5 kW for heavy duty
<b>Continuous Output Current</b>	23.5 A at 4 kHz for normal duty 16.5 A at 4 kHz for heavy duty
<b>Emc Filter</b>	Integrated With EMC plate option
<b>Ip Degree Of Protection</b>	IP55
<b>Degree Of Protection</b>	UL type 1
<b>Option Module</b>	Slot A: communication module for Profibus DP V1 Slot A: communication module for PROFINET Slot A: communication module for DeviceNet Slot A: communication module for EtherCAT Slot A: communication module for CANopen daisy chain RJ45 Slot A: communication module for CANopen SUB-D 9 Slot A: communication module for CANopen screw terminals Slot A/slot B/slot C: digital and analog I/O extension module Slot A/slot B/slot C: output relay extension module Slot B: 5/12 V digital encoder interface module Slot B: analog encoder interface module Slot B: resolver encoder interface module communication module for Ethernet Powerlink
<b>Discrete Input Logic</b>	16 preset speeds
<b>Asynchronous Motor Control Profile</b>	Variable torque standard Constant torque standard Optimized torque mode
<b>Synchronous Motor Control Profile</b>	Permanent magnet motor Synchronous reluctance motor

Excluding VAT and subject to change. Please check with your local distributor through "Where to buy"

<b>Maximum Output Frequency</b>	599 Hz
<b>Switching Frequency</b>	2...16 kHz adjustable 4...16 kHz with derating factor
<b>Nominal Switching Frequency</b>	4 kHz
<b>Line Current</b>	19.8 A at 380 V (normal duty) 14.1 A at 380 V (heavy duty) 17.0 A at 480 V (normal duty) 12.5 A at 480 V (heavy duty)
<b>Apparent Power</b>	14.1 kVA at 480 V (normal duty) 10.4 kVA at 480 V (heavy duty)
<b>Maximum Transient Current</b>	28.2 A during 60 s (normal duty) 24.8 A during 60 s (heavy duty)
<b>Network Frequency</b>	50...60 Hz
<b>Prospective Line Isc</b>	50 kA

## Complementary

<b>Discrete Input Number</b>	10
<b>Discrete Input Type</b>	DI1...DI8 programmable, 24 V DC ( $\leq 30$ V), impedance: 3.5 kOhm DI7, DI8 programmable as pulse input: 0...30 kHz, 24 V DC ( $\leq 30$ V) STOA, STOB safe torque off, 24 V DC ( $\leq 30$ V), impedance: $> 2.2$ kOhm
<b>Discrete Output Number</b>	2
<b>Discrete Output Type</b>	Logic output DQ+ 0...1 kHz $\leq 30$ V DC 100 mA Programmable as pulse output DQ+ 0...30 kHz $\leq 30$ V DC 20 mA Logic output DQ- 0...1 kHz $\leq 30$ V DC 100 mA
<b>Analogue Input Number</b>	3
<b>Analogue Input Type</b>	AI1, AI2, AI3 software-configurable voltage: 0...10 V DC, impedance: 30 kOhm, resolution 12 bits AI1, AI2, AI3 software-configurable current: 0...20 mA/4...20 mA, impedance: 250 Ohm, resolution 12 bits
<b>Analogue Output Number</b>	2
<b>Analogue Output Type</b>	Software-configurable voltage AQ1, AQ2: 0...10 V DC impedance 470 Ohm, resolution 10 bits Software-configurable current AQ1, AQ2: 0...20 mA impedance 500 Ohm, resolution 10 bits
<b>Relay Output Number</b>	3
<b>Relay Output Type</b>	Configurable relay logic R1: fault relay NO/NC electrical durability 100000 cycles Configurable relay logic R2: sequence relay NO electrical durability 1000000 cycles Configurable relay logic R3: sequence relay NO electrical durability 1000000 cycles
<b>Maximum Switching Current</b>	Relay output R1 on resistive load, $\cos \phi = 1$ : 3 A at 250 V AC Relay output R1 on resistive load, $\cos \phi = 1$ : 3 A at 30 V DC Relay output R1 on inductive load, $\cos \phi = 0.4$ and $L/R = 7$ ms: 2 A at 250 V AC Relay output R1 on inductive load, $\cos \phi = 0.4$ and $L/R = 7$ ms: 2 A at 30 V DC Relay output R2, R3 on resistive load, $\cos \phi = 1$ : 5 A at 250 V AC Relay output R2, R3 on resistive load, $\cos \phi = 1$ : 5 A at 30 V DC Relay output R2, R3 on inductive load, $\cos \phi = 0.4$ and $L/R = 7$ ms: 2 A at 250 V AC Relay output R2, R3 on inductive load, $\cos \phi = 0.4$ and $L/R = 7$ ms: 2 A at 30 V DC
<b>Minimum Switching Current</b>	Relay output R1, R2, R3: 5 mA at 24 V DC
<b>Physical Interface</b>	Ethernet 2-wire RS 485
<b>Connector Type</b>	2 RJ45 1 RJ45
<b>Method Of Access</b>	Slave Modbus TCP

<b>Transmission Rate</b>	10, 100 Mbits 4.8 kbps 9600 bit/s 19200 bit/s
<b>Transmission Frame</b>	RTU
<b>Number Of Addresses</b>	1...247
<b>Data Format</b>	8 bits, configurable odd, even or no parity
<b>Type Of Polarization</b>	No impedance
<b>4 Quadrant Operation Possible</b>	True
<b>Acceleration And Deceleration Ramps</b>	Linear adjustable separately from 0.01...9999 s
<b>Motor Slip Compensation</b>	Adjustable Automatic whatever the load Not available in permanent magnet motor law Can be suppressed
<b>Braking To Standstill</b>	By DC injection
<b>Brake Chopper Integrated</b>	True
<b>Maximum Input Current</b>	19.8 A
<b>Maximum Output Voltage</b>	480.0 V
<b>Relative Symmetric Network Frequency Tolerance</b>	5 %
<b>Base Load Current At High Overload</b>	16.5 A
<b>Base Load Current At Low Overload</b>	23.5 A
<b>With Safety Function Safely Limited Speed (Sls)</b>	True
<b>With Safety Function Safe Brake Management (Sbc/Sbt)</b>	True
<b>With Safety Function Safe Operating Stop (Sos)</b>	False
<b>With Safety Function Safe Position (Sp)</b>	False
<b>With Safety Function Safe Programmable Logic</b>	False
<b>With Safety Function Safe Speed Monitor (Ssm)</b>	False
<b>With Safety Function Safe Stop 1 (Ss1)</b>	True
<b>With Sft Fct Safe Stop 2 (Ss2)</b>	False
<b>With Safety Function Safe Torque Off (Sto)</b>	True
<b>With Safety Function Safely Limited Position (Slp)</b>	False
<b>With Safety Function Safe Direction (Sdi)</b>	False
<b>Protection Type</b>	Thermal protection: motor Safe torque off: motor Motor phase break: motor Thermal protection: drive Safe torque off: drive Overheating: drive Overcurrent between output phases and earth: drive Overload of output voltage: drive Short-circuit protection: drive Motor phase break: drive Overvoltages on the DC bus: drive Line supply overvoltage: drive Line supply undervoltage: drive Line supply phase loss: drive Overspeed: drive Break on the control circuit: drive
<b>Quantity Per Set</b>	1

<b>Width</b>	264 mm
<b>Height</b>	678 mm
<b>Depth</b>	330 mm
<b>Net Weight</b>	13.7 kg
<b>Electrical Connection</b>	Control: screw terminal 0.5...1.5 mm <sup>2</sup> Line side: screw terminal 6 mm <sup>2</sup> Motor: screw terminal 6...10 mm <sup>2</sup> DC bus: screw terminal 6...10 mm <sup>2</sup>
<b>Transmission Rate</b>	10/100 Mbit/s for Ethernet IP/Modbus TCP 4.8, 9.6, 19.2, 38.4 kbit/s for Modbus serial
<b>Exchange Mode</b>	Half duplex, full duplex, autonegotiation Ethernet IP/Modbus TCP
<b>Data Format</b>	8 bits, configurable odd, even or no parity for Modbus serial
<b>Type Of Polarization</b>	No impedance for Modbus serial
<b>Number Of Addresses</b>	1...247 for Modbus serial
<b>Supply</b>	External supply for digital inputs: 24 V DC (19...30 V), <1.25 mA, protection type: overload and short-circuit protection Internal supply for reference potentiometer (1 to 10 kOhm): 10.5 V DC +/- 5 %, <10 mA, protection type: overload and short-circuit protection Internal supply for digital inputs and STO: 24 V DC (21...27 V), <200 mA, protection type: overload and short-circuit protection
<b>Local Signalling</b>	Local diagnostic: 3 LED (mono/dual colour) Embedded communication status: 5 LED (dual colour) Communication module status: 2 LED (dual colour) Presence of voltage: 1 LED (red)
<b>Input Compatibility</b>	DI1...DI8: discrete input level 1 PLC conforming to IEC 61131-2 DI7, DI8: pulse input level 1 PLC conforming to IEC 65A-68 STOA, STOB: discrete input level 1 PLC conforming to IEC 61131-2
<b>Discrete Input Logic</b>	Positive logic (source) (DI1...DI8), < 5 V (state 0), > 11 V (state 1) Negative logic (sink) (DI1...DI8), > 16 V (state 0), < 10 V (state 1) Positive logic (source) (DI7, DI8), < 0.6 V (state 0), > 2.5 V (state 1) Positive logic (source) (STOA, STOB), < 5 V (state 0), > 11 V (state 1)
<b>Sampling Duration</b>	2 ms +/- 0.5 ms (DI1...DI8) - discrete input 5 ms +/- 1 ms (DI7, DI8) - pulse input 1 ms +/- 1 ms (AI1, AI2, AI3) - analog input 5 ms +/- 1 ms (AQ1, AQ2) - analog output
<b>Accuracy</b>	+/- 0.6 % AI1, AI2, AI3 for a temperature variation 60 °C analog input +/- 1 % AQ1, AQ2 for a temperature variation 60 °C analog output
<b>Linearity Error</b>	AI1, AI2, AI3: +/- 0.15 % of maximum value for analog input AQ1, AQ2: +/- 0.2 % for analog output
<b>Refresh Time</b>	Relay output (R1, R2, R3): 5 ms (+/- 0.5 ms)
<b>Isolation</b>	Between power and control terminals

## Environment

<b>Operating Altitude</b>	<= 1000 m without derating 1000...4800 m with current derating 1 % per 100 m
<b>Operating Position</b>	Vertical +/- 10 degree
<b>Product Certifications</b>	TÜV
<b>Marking</b>	CE
<b>Standards</b>	UL 508C IEC 61800-3 IEC 61800-5-1 IEC 61000-3-12 IEC 60721-3 IEC 61508 IEC 13849-1

<b>Maximum Thdi</b>	<48 % from 80...100 % of load conforming to IEC 61000-3-12
<b>Assembly Style</b>	Enclosed
<b>Electromagnetic Compatibility</b>	Electrostatic discharge immunity test level 3 conforming to IEC 61000-4-2 Radiated radio-frequency electromagnetic field immunity test level 3 conforming to IEC 61000-4-3 Electrical fast transient/burst immunity test level 4 conforming to IEC 61000-4-4 1.2/50 $\mu$ s - 8/20 $\mu$ s surge immunity test level 3 conforming to IEC 61000-4-5 Conducted radio-frequency immunity test level 3 conforming to IEC 61000-4-6
<b>Environmental Class (During Operation)</b>	Class 3C3 according to IEC 60721-3-3 Class 3S3 according to IEC 60721-3-3
<b>Maximum Acceleration Under Shock Impact (During Operation)</b>	150 m/s <sup>2</sup> at 11 ms
<b>Maximum Acceleration Under Vibrational Stress (During Operation)</b>	10 m/s <sup>2</sup> at 13...200 Hz
<b>Maximum Deflection Under Vibratory Load (During Operation)</b>	1.5 mm at 2...13 Hz
<b>Permitted Relative Humidity (During Operation)</b>	Class 3K5 according to EN 60721-3
<b>Overvoltage Category</b>	III
<b>Regulation Loop</b>	Adjustable PID regulator
<b>Insulation Resistance</b>	> 1 MOhm 500 V DC for 1 minute to earth
<b>Noise Level</b>	52 dB conforming to 86/188/EEC
<b>Vibration Resistance</b>	1.5 mm peak to peak (f= 2...13 Hz) conforming to IEC 60068-2-6 1 gn (f= 13...200 Hz) conforming to IEC 60068-2-6
<b>Shock Resistance</b>	15 gn for 11 ms conforming to IEC 60068-2-27
<b>Environmental Characteristic</b>	Chemical pollution resistance class 3C3 conforming to IEC 60721-3-3 Dust pollution resistance class 3S3 conforming to IEC 60721-3-3
<b>Relative Humidity</b>	5...95 % without condensation conforming to IEC 60068-2-3
<b>Ambient Air Temperature For Operation</b>	-15...40 °C (without derating) 40...50 °C (with derating factor)
<b>Noise Level</b>	52 dB
<b>Pollution Degree</b>	2
<b>Ambient Air Transport Temperature</b>	-40...70 °C
<b>Ambient Air Temperature For Storage</b>	-40...70 °C

## Packing Units

<b>Unit Type Of Package 1</b>	PCE
<b>Number Of Units In Package 1</b>	1
<b>Package 1 Height</b>	40.0 cm
<b>Package 1 Width</b>	39.0 cm
<b>Package 1 Length</b>	80.0 cm
<b>Package 1 Weight</b>	17.1 kg

## Sustainability

**Green Premium™ label** is Schneider Electric's commitment to delivering products with best-in-class environmental performance. Green Premium promises compliance with the latest regulations, transparency on environmental impacts, as well as circular and low-CO<sub>2</sub> products.

**Guide to assessing product sustainability** is a white paper that clarifies global eco-label standards and how to interpret environmental declarations.

[Learn more about Green Premium >](#)

[Guide to assess a product's sustainability >](#)



Transparency RoHS/REACH

## Resource performance

Upgraded Components Available

## Well-being performance

Mercury Free

Rohs Exemption Information Yes

## Certifications & Standards

Reach Regulation [REACH Declaration](#)

Eu Rohs Directive Pro-active compliance (Product out of EU RoHS legal scope)

China Rohs Regulation [China RoHS declaration](#)

Environmental Disclosure [Product Environmental Profile](#)

Weee The product must be disposed on European Union markets following specific waste collection and never end up in rubbish bins

Circularity Profile [End of Life Information](#)

Dimensions Drawings

## Dimensions

---

Front and Left View

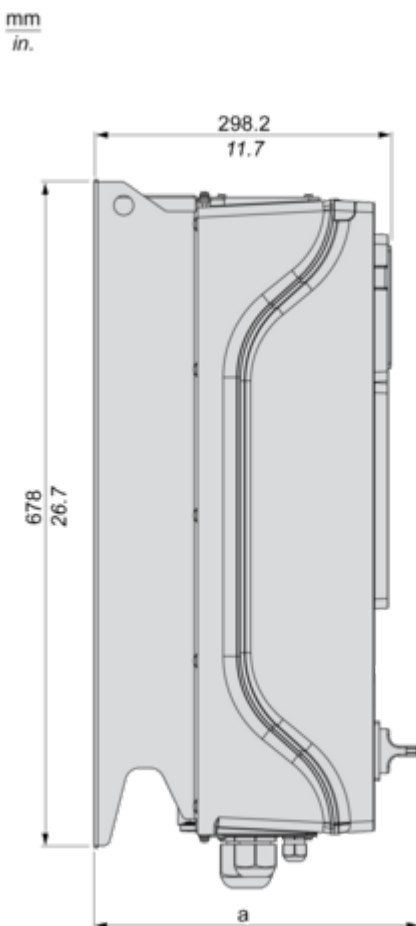
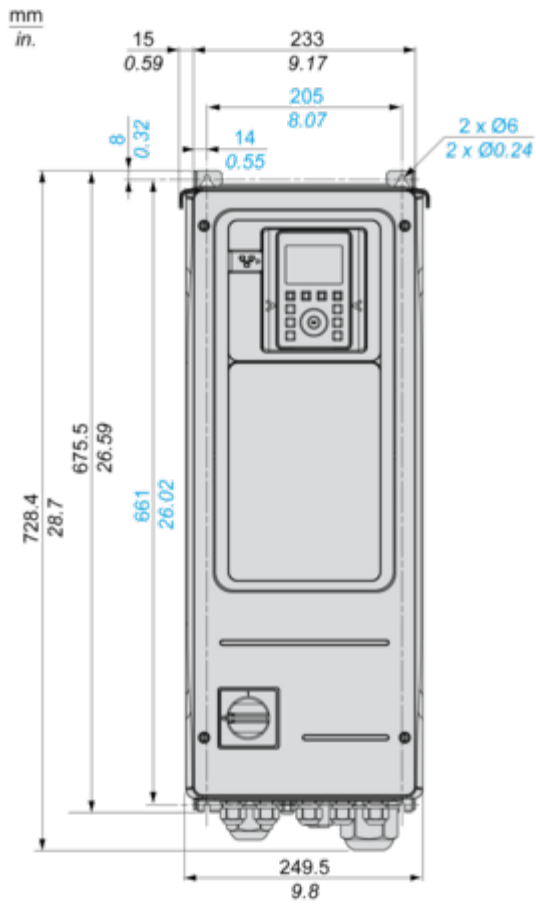

a = 330 mm (11.8 in.)



Mounting and Clearance

Clearances



X1	X2	X3
≥ 100 mm (3.94 in.)	≥ 100 mm (3.94 in.)	≥ 10 mm (0.39 in.)

- Mount the device in a vertical position ( $\pm 10^\circ$ ). This is required for cooling the device.
- Do not mount the device close to heat sources.
- Leave sufficient free space so that the air required for cooling purposes can circulate from the bottom to the top of the drive.

Connections and Schema

**Three-Phase Power Supply with Upstream Breaking via Line Contactor**

Connection diagrams conforming to standards EN 954-1 category 1 and IEC/EN 61508 capacity SIL1, stopping category 0 in accordance with standard IEC/EN 60204-1

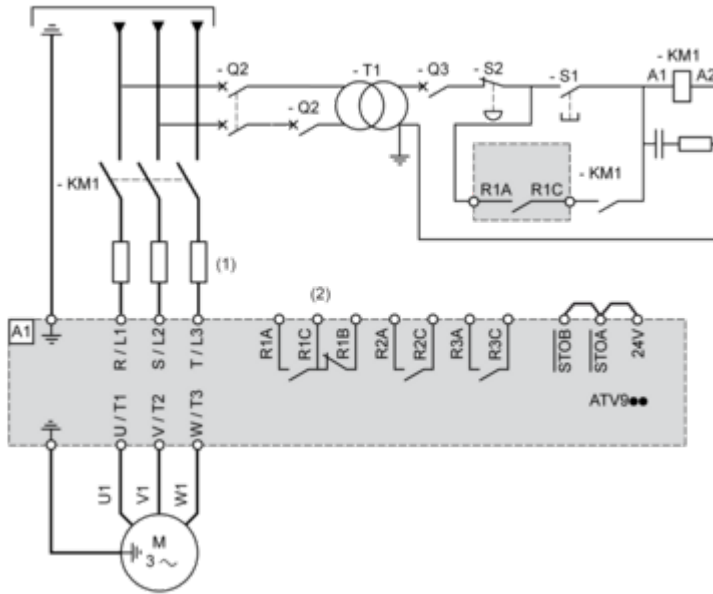

(1) Line choke if used

(2) Use relay R1 set to operating state Fault to switch Off the product once an error is detected.

A1 : Drive

KM1 : Line Contactor

Q2, Q3 : Circuit breakers

S1, S2 : Pushbuttons

T1 : Transformer for control part

**Three-Phase Power Supply with Downstream Breaking via Contactor**

Connection diagrams conforming to standards EN 954-1 category 1 and IEC/EN 61508 capacity SIL1, stopping category 0 in accordance with standard IEC/EN 60204-1

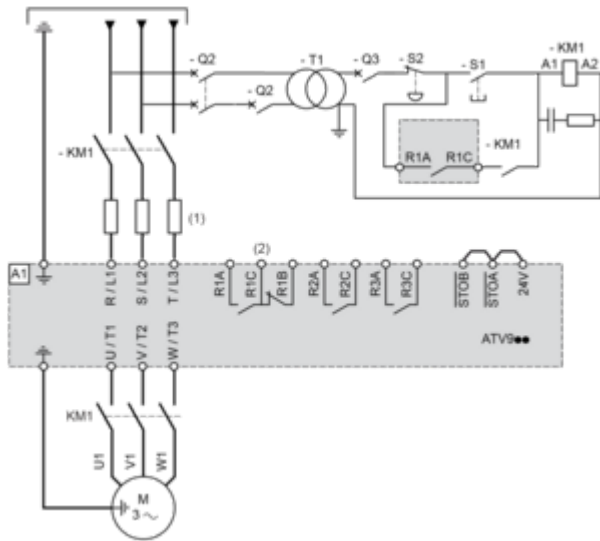

(1) Line choke if used

(2) Use relay R1 set to operating state Fault to switch Off the product once an error is detected.

A1 : Drive

KM1 : Contactor

Control Block Wiring Diagram

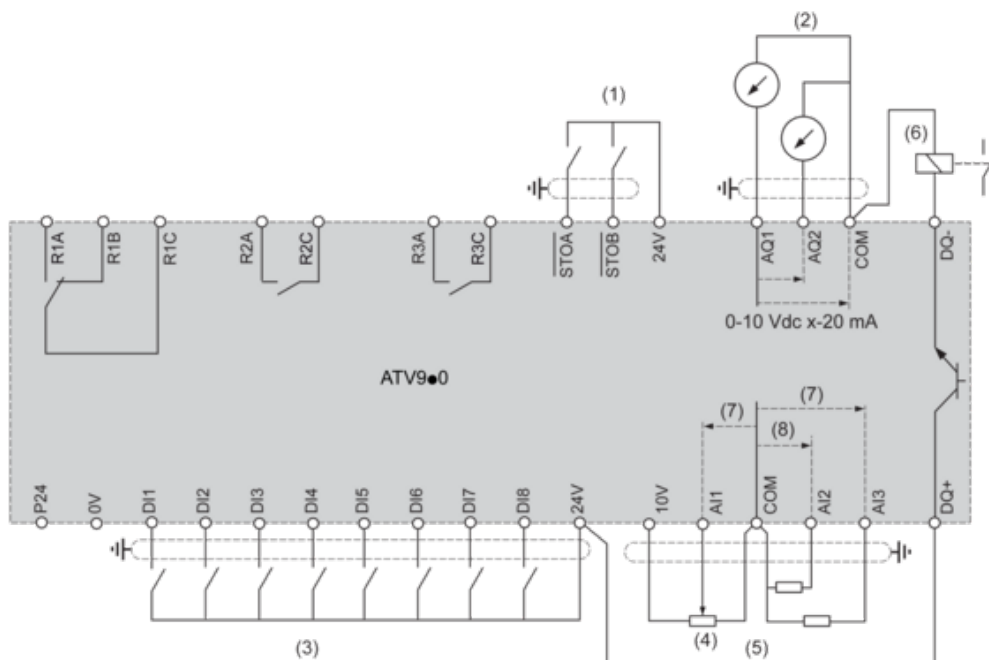

- (1) Safe Torque Off
  - (2) Analog Output
  - (3) Digital Input
  - (4) Reference potentiometer
  - (5) Analog Input
  - (6) Digital Output
  - (7) 0-10 Vdc, x-20 mA
  - (8) 0-10 Vdc, -10 Vdc...+10 Vdc
- R1A, R1B, R1C** : Fault relay  
**R2A, R2C** : Sequence relay  
**R3A, R3C** : Sequence relay

Sensor Connection

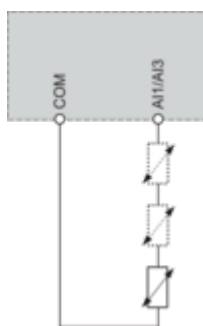

It is possible to connect either 1 or 3 sensors on terminals AI1 or AI3

**Sink / Source Switch Configuration**

The switch is used to adapt the operation of the logic inputs to the technology of the programmable controller outputs.

- Set the switch to Source (factory setting) if using PLC outputs with PNP transistors.
- Set the switch to Ext if using PLC outputs with NPN transistors.

**Switch Set to SRC (Source) Position Using the Output Power Supply for the Digital Inputs**

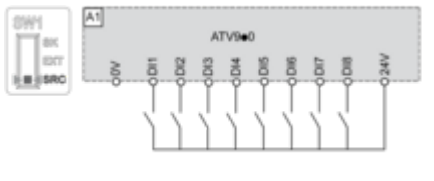

**Switch Set to SRC (Source) Position and Use of an External Power Supply for the DIs**

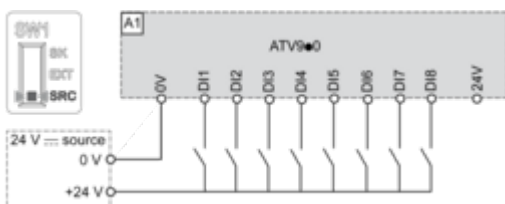

**Switch Set to SK (Sink) Position Using the Output Power Supply for the Digital Inputs**

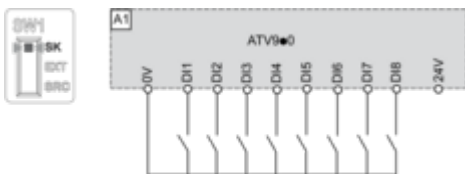

**Switch Set to EXT Position Using an External Power Supply for the DIs**

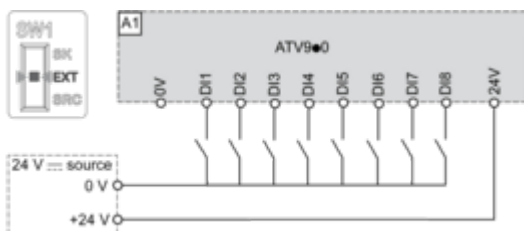

Performance Curves

Derating Curves

---

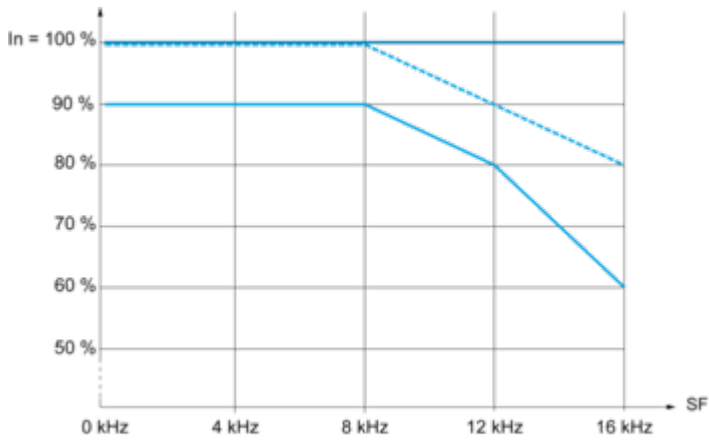

- 40 °C (104 °F)
  - 45 °C (113 °F)
  - 50 °C (122 °F)
- In : Nominal Drive Current  
SF : Switching Frequency