

# Product datasheet

Specifications



## Variable speed drive. Altivar Process ATV900. High Performance System ATV960. 400/315 kW. 400 V. IP23

ATV960C40Q4X1

**Price: 1,032,356.66 ZAR**

### Main

<b>Device Application</b>	Industrial application
<b>Device Short Name</b>	ATV960
<b>Product Destination</b>	Synchronous motors Asynchronous motors
<b>Provided Equipment</b>	Enclosure Spacial SF Graphical operating panel in the enclosure door Frequency inverter Main switch Line choke Terminal block main supply Terminal block motor
<b>Colour Of Enclosure</b>	Light grey (RAL 7035)
<b>Ip Degree Of Protection</b>	IP23 conforming to IEC 61800-5-1
<b>Type Of Cooling</b>	Forced convection
<b>Supply Frequency</b>	50/60 Hz +/- 5 %
<b>Network Number Of Phases</b>	3 phases
<b>Output Voltage</b>	<= power supply voltage
<b>Permissible Temporary Current Boost</b>	1.2 x In during 60 s (normal duty) 1.5 x In during 60 s (heavy duty)
<b>Speed Drive Output Frequency</b>	0.1...599 Hz
<b>Continuous Output Current</b>	730 A at 2.5 kHz for normal duty 590 A at 2.5 kHz for heavy duty
<b>Power Dissipation In W</b>	9900 W, total (normal duty) 7370 W, total (heavy duty) 1120 W, control part (normal duty) 770 W, control part (heavy duty)
<b>Volume Of Cooling Air</b>	280 m3/h for control 1740 m3/h for power
<b>Noise Level</b>	71 dB conforming to 86/188/EEC - physical agents (noise) directive
<b>Prospective Line Isc</b>	50 kA for 100 ms
<b>Motor Recommended Cable Cross Section</b>	3 x (3 x 120 mm <sup>2</sup> ) (heavy duty) 3 x (3 x 185 mm <sup>2</sup> ) (normal duty) 4 x (3 x 120 mm <sup>2</sup> ) (normal duty) 4 x (3 x 95 mm <sup>2</sup> ) (heavy duty)
<b>Height</b>	2150 mm
<b>Depth</b>	664 mm

Excluding VAT and subject to change. Please check with your local distributor through "Where to buy"

<b>Option Module</b>	Slot A: communication module for Profibus DP V1 Slot A: communication module for PROFINET Slot A: communication module for DeviceNet Slot A: communication module for EtherCAT Slot A: communication module for CANopen daisy chain RJ45 Slot A: communication module for CANopen SUB-D 9 Slot A: communication module for CANopen screw terminals Slot A/slot B/slot C: digital and analog I/O extension module Slot A/slot B/slot C: output relay extension module Slot B: 5/12 V digital encoder interface module Slot B: analog encoder interface module Slot B: resolver encoder interface module
<b>Safety Function</b>	STO (safe torque off), level SIL 3 for $\leq 100$ ms
<b>Emc Filter</b>	Integrated conforming to EN/IEC 61800-3, category C3, shielded cable with 50 m Integrated conforming to EN/IEC 61800-3, category C4, unshielded cable with 80 m
<b>Range Of Product</b>	Altivar Process ATV900
<b>Product Or Component Type</b>	Variable speed drive
<b>Communication Port Protocol</b>	Modbus TCP EtherNet/IP Modbus serial
<b>[Us] Rated Supply Voltage</b>	380...415 V - 10...6 %
<b>Motor Power Kw</b>	400 kW for normal duty 315 kW for heavy duty

## Complementary

<b>Protection Type</b>	Motor: thermal protection Motor: safe torque off Motor: motor phase break Drive: thermal protection Drive: safe torque off Drive: overheating Drive: overcurrent (between output phases and earth) Drive: overload (output) Drive: short-circuit protection Drive: motor phase break Drive: overvoltage (DC bus) Drive: line supply overvoltage Drive: line supply undervoltage Drive: line supply phase loss Drive: overspeed Drive: break on the control circuit Drive: short-circuit protection with semi-conductor fuse (main supply) Drive: fan monitoring
<b>Frequency Resolution</b>	Display unit: 0.1 Hz Analog input: 0.012/50 Hz
<b>Connector Type</b>	2 RJ45 for Ethernet IP/Modbus TCP on the control block 1 RJ45 for Modbus serial on the control block
<b>Physical Interface</b>	2-wire RS 485 for Modbus serial
<b>Transmission Frame</b>	RTU for Modbus serial
<b>Transmission Rate</b>	10/100 Mbit/s for Ethernet IP/Modbus TCP 4.8, 9.6, 19.2, 38.4 kbit/s for Modbus serial
<b>Exchange Mode</b>	Half duplex, full duplex, autonegotiation Ethernet IP/Modbus TCP
<b>Data Format</b>	8 bits, configurable odd, even or no parity for Modbus serial
<b>Type Of Polarization</b>	No impedance for Modbus serial
<b>Number Of Addresses</b>	1...247 for Modbus serial
<b>Supply</b>	External supply for digital inputs: 24 V DC (19...30 V), $<1.25$ mA, protection type: overload and short-circuit protection Internal supply for reference potentiometer (1 to 10 kOhm): 10.5 V DC $\pm 5\%$ , $<10$ mA, protection type: overload and short-circuit protection Internal supply for digital inputs and STO: 24 V DC (21...27 V), $<200$ mA, protection type: overload and short-circuit protection

<b>Local Signalling</b>	LCD display unit front door operation function, status and configuration
<b>Input Compatibility</b>	DI1...DI8: discrete input level 1 PLC conforming to EN/IEC 61131-2 DI7, DI8: pulse input level 1 PLC conforming to IEC 65A-68 STOA, STOB: discrete input level 1 PLC conforming to EN/IEC 61131-2
<b>Discrete Input Logic</b>	Positive logic (source) (DI1...DI8), < 5 V (state 0), > 11 V (state 1) Negative logic (sink) (DI1...DI8), > 16 V (state 0), < 10 V (state 1) Positive logic (source) (DI7, DI8), < 0.6 V (state 0), > 2.5 V (state 1) Positive logic (source) (STOA, STOB), < 5 V (state 0), > 11 V (state 1)
<b>Sampling Duration</b>	2 ms +/- 0.5 ms (DI1...DI8) - discrete input 5 ms +/- 1 ms (DI7, DI8) - pulse input 1 ms +/- 1 ms (AI1, AI2, AI3) - analog input 5 ms +/- 1 ms (AQ1, AQ2) - analog output
<b>Accuracy</b>	+/- 0.6 % AI1, AI2, AI3 for a temperature variation 60 °C analog input +/- 1 % AQ1, AQ2 for a temperature variation 60 °C analog output
<b>Linearity Error</b>	AI1, AI2, AI3: +/- 0.15 % of maximum value for analog input AQ1, AQ2: +/- 0.2 % for analog output
<b>Refresh Time</b>	Relay output (R1, R2, R3): 5 ms (+/- 0.5 ms)
<b>Isolation</b>	Between power and control terminals
<b>Discrete Input Number</b>	10
<b>Discrete Input Type</b>	DI1...DI8 programmable, 24 V DC (<= 30 V), impedance: 3.5 kOhm DI7, DI8 programmable as pulse input: 0...30 kHz, 24 V DC (<= 30 V) STOA, STOB safe torque off, 24 V DC (<= 30 V), impedance: > 2.2 kOhm
<b>Discrete Input Logic</b>	16 preset speeds
<b>Discrete Output Number</b>	2
<b>Discrete Output Type</b>	Logic output DQ+ 0...1 kHz <= 30 V DC 100 mA Programmable as pulse output DQ+ 0...30 kHz <= 30 V DC 100 mA Logic output DQ- 0...1 kHz <= 30 V DC 100 mA
<b>Analogue Input Number</b>	3
<b>Analogue Input Type</b>	AI1, AI2, AI3 software-configurable voltage: 0...10 V DC, impedance: 30 kOhm, resolution 12 bits AI1, AI2, AI3 software-configurable current: 0...20 mA, impedance: 250 Ohm, resolution 12 bits
<b>Analogue Output Number</b>	2
<b>Analogue Output Type</b>	Software-configurable voltage AQ1, AQ2: 0...10 V DC impedance 470 Ohm, resolution 10 bits Software-configurable current AQ1, AQ2: 0...20 mA impedance 500 Ohm, resolution 10 bits
<b>Relay Output Number</b>	3
<b>Relay Output Type</b>	Configurable relay logic R1: fault relay NO/NC electrical durability 100000 cycles Configurable relay logic R2: sequence relay NO electrical durability 1000000 cycles Configurable relay logic R3: sequence relay NO electrical durability 1000000 cycles
<b>Maximum Switching Current</b>	Relay output R1 on resistive load, cos phi = 1: 3 mA at 250 V AC Relay output R1 on resistive load, cos phi = 1: 3 mA at 30 V DC Relay output R1 on inductive load, cos phi = 0.4 and L/R = 7 ms: 2 mA at 250 V AC Relay output R1 on inductive load, cos phi = 0.4 and L/R = 7 ms: 2 mA at 30 V DC Relay output R2, R3 on resistive load, cos phi = 1: 5 mA at 250 V AC Relay output R2, R3 on resistive load, cos phi = 1: 5 mA at 30 V DC Relay output R2, R3 on inductive load, cos phi = 0.4 and L/R = 7 ms: 2 mA at 250 V AC Relay output R2, R3 on inductive load, cos phi = 0.4 and L/R = 7 ms: 2 mA at 30 V DC
<b>Minimum Switching Current</b>	Relay output R1, R2, R3: 5 mA at 24 V DC
<b>Method Of Access</b>	Slave Modbus TCP
<b>Asynchronous Motor Control Profile</b>	Optimized torque mode Variable torque standard Constant torque standard
<b>Synchronous Motor Control Profile</b>	Permanent magnet motor

<b>Acceleration And Deceleration Ramps</b>	S, U or customized Linear adjustable separately from 0.01 to 9000 s
<b>Motor Slip Compensation</b>	Can be suppressed Adjustable Automatic whatever the load Not available in permanent magnet motor law
<b>Switching Frequency</b>	2...8 kHz adjustable with derating factor
<b>Nominal Switching Frequency</b>	2.5 kHz
<b>Braking To Standstill</b>	By DC injection
<b>Line Current</b>	681 A at 400 V (normal duty) 545 A at 400 V (heavy duty)
<b>Apparent Power</b>	472 kVA at 400 V (normal duty) 378 kVA at 400 V (heavy duty)
<b>Maximum Transient Current</b>	876 A during 60 s per 10 min (normal duty) 885 A during 60 s per 10 min (heavy duty)
<b>Short-Circuit Protection</b>	Upstream: 800 A gG fuse (normal duty) Upstream: 630 A gG fuse (heavy duty) Internal: 315 A 3 aR fuse
<b>Electrical Connection</b>	Removable screw terminals, clamping capacity: 0.5...1.5 mm <sup>2</sup> for control M12 bar for main supply M12 bar for motor
<b>Cable Entry</b>	Bottom
<b>Width</b>	800 mm
<b>Net Weight</b>	650 kg

## Environment

<b>Insulation Resistance</b>	> 1 MOhm 500 V DC for 1 minute to earth
<b>Pollution Degree</b>	2 conforming to EN/IEC 61800-5-1
<b>Vibration Resistance</b>	1.5 mm peak to peak (f= 3...10 Hz) conforming to IEC 60068-2-6 0.6 gn (f= 10...200 Hz) conforming to IEC 60068-2-6 3M3 conforming to IEC 60721-3-3
<b>Shock Resistance</b>	4 gn for 11 ms conforming to IEC 60068-2-27 3M2 conforming to IEC 60721-3-3
<b>Relative Humidity</b>	5...95 % without condensation conforming to IEC 60068-2-3
<b>Operating Altitude</b>	< 1000 m without derating 1000...2000 m with current derating 1 % per 100 m 2000...3800 m with current derating 1 % per 100 m for TT earthing system 2000...3800 m with current derating 1 % per 100 m for TN earthing system 2000...3800 m with current derating 1 % per 100 m for IT earthing system 3800...4800 m with current derating 1 % per 100 m for TT earthing system 3800...4800 m with current derating 1 % per 100 m for TN earthing system
<b>Environmental Characteristic</b>	Chemical pollution resistance class 3C3 conforming to EN/IEC 60721-3-3 Dust pollution resistance class 3S3 conforming to EN/IEC 60721-3-3 Humidity resistant class 3K3 conforming to EN/IEC 60721-3-3
<b>Product Certifications</b>	ATEX C-Tick EAC
<b>Operating Position</b>	Vertical +/- 10 degree
<b>Marking</b>	CE
<b>Standards</b>	EN/IEC 61800-3 EN/IEC 61800-2 EN/IEC 61800-5-1 EN/IEC 60204-1
<b>Maximum Thdi</b>	<48 % full load conforming to IEC 61000-3-12

<b>Assembly Style</b>	In floor-standing enclosure compact version
<b>Electromagnetic Compatibility</b>	Electrostatic discharge immunity test level 3 conforming to IEC 61000-4-2 Radiated radio-frequency electromagnetic field immunity test level 3 conforming to IEC 61000-4-3 Electrical fast transient/burst immunity test level 4 conforming to IEC 61000-4-4 1.2/50 $\mu$ s - 8/20 $\mu$ s surge immunity test level 3 conforming to IEC 61000-4-5 Conducted radio-frequency immunity test level 3 conforming to IEC 61000-4-6
<b>Overvoltage Category</b>	III
<b>Ambient Air Temperature For Operation</b>	-10...0 °C without derating (with option enclosure heating) 0...40 °C without derating 40...50 °C with derating factor
<b>Ambient Air Temperature For Storage</b>	-25...70 °C

## Packing Units

<b>Unit Type Of Package 1</b>	PCE
<b>Number Of Units In Package 1</b>	1
<b>Package 1 Height</b>	215 cm
<b>Package 1 Width</b>	66.9 cm
<b>Package 1 Length</b>	80 cm
<b>Package 1 Weight</b>	700 kg
<b>Unit Type Of Package 2</b>	CAR
<b>Number Of Units In Package 2</b>	1
<b>Package 2 Height</b>	230 cm
<b>Package 2 Width</b>	80 cm
<b>Package 2 Length</b>	95 cm
<b>Package 2 Weight</b>	700 kg

## Sustainability

**Green Premium™ label** is Schneider Electric's commitment to delivering products with best-in-class environmental performance. Green Premium promises compliance with the latest regulations, transparency on environmental impacts, as well as circular and low-CO<sub>2</sub> products.

**Guide to assessing product sustainability** is a white paper that clarifies global eco-label standards and how to interpret environmental declarations.

[Learn more about Green Premium >](#)

[Guide to assess a product's sustainability >](#)



Take-back

## Resource performance

✓ Take-Back Program Available

---

## Well-being performance

✓ Mercury Free

---

✓ Rohs Exemption Information Yes

---

Reach Regulation [REACH Declaration](#)

---

Eu Rohs Directive Pro-active compliance (Product out of EU RoHS legal scope)

---

China Rohs Regulation [China RoHS declaration](#)

---

Weee The product must be disposed on European Union markets following specific waste collection and never end up in rubbish bins

---

Dimensions Drawings

Dimensions

---

Right and Front Views

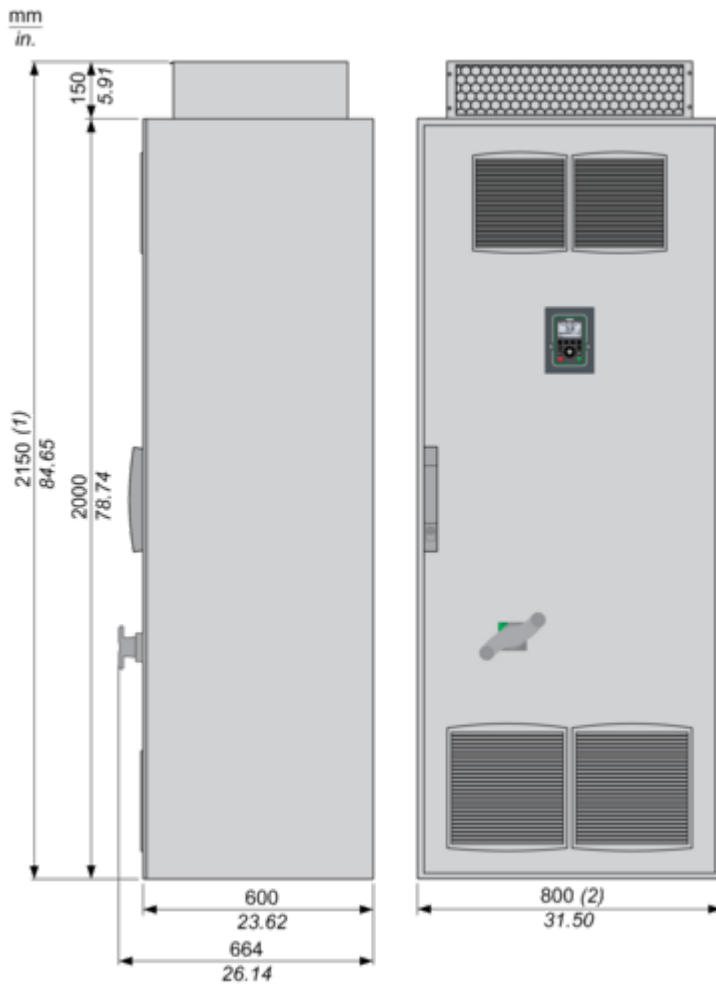

(1) + 200 mm / 7.87 in. with option enclosure plinth or increased protection degree IP54  
 (2) + 600 mm / 23.62 in. with option connection enclosure cable from top/bottom

Mounting and Clearance

Mounting and Clearance

---



(1) Air inflow temperature: -10...+50 °C (below 0 °C with option enclosure heating, above +40 °C with derating).

Connections and Schema

Typical Wiring of the Frequency Inverter

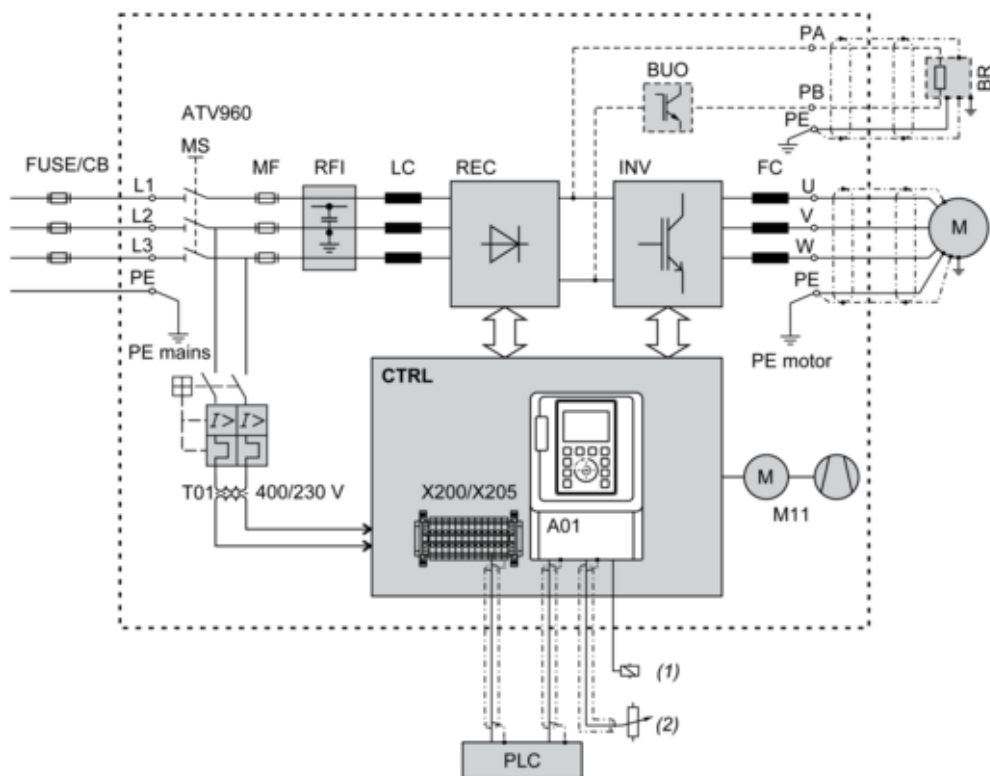

(1) Relay control

(2) Reference value

**FUSE/CB** External pre-fuse or circuit breaker to protect the main cable

**MS** Built-in main switch, lockable in open position

**T01** Control transformer 400 / 230 V AC

**MF** aR fuse for short-circuit shut-down if the electronic protective devices do not work properly

**Clean Power Filter** Clean Power Filter with integrated EMC filter

**LC** Filter choke

**AIC** Active Infeed Converter module(s)

**INV** Inverter module(s)

**FC** dv/dt filter choke to reduce the voltage load of the motor (at some types a "dv/dt filter choke" is already integrated)

**CTRL** Control panel with control block and further control components

**A01** Control terminals at the control block

**X200 / X205** Control terminals at the control panel

**M11** Fan in enclosure door

**BUO** Braking unit option

**BR** Braking resistor (option)

### Structure of the Control Block

---

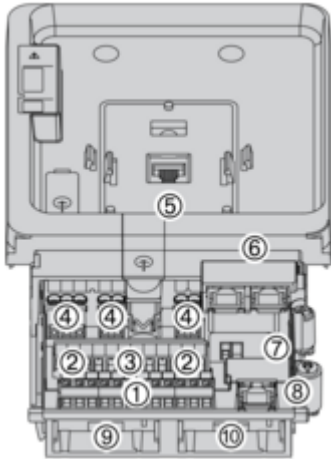

- (1) Control terminals of digital inputs
- (2) Control terminals STO (Safe Torque Off) and analog outputs
- (3) Control terminals of analog inputs
- (4) Control terminals of relay outputs
- (5) RJ45 port for the graphical keypad
- (6) Dual port RJ45 for Ethernet IP or Modbus TCP
- (7) Sink-Ext-Source selector switch and PTO/DQ selector switch
- (8) RJ45 port for serial Modbus
- (9) Slot B for I/O expansion card or encoder interface module
- (10) Slot A for communication card or I/O expansion card

Control Block Wiring Diagram

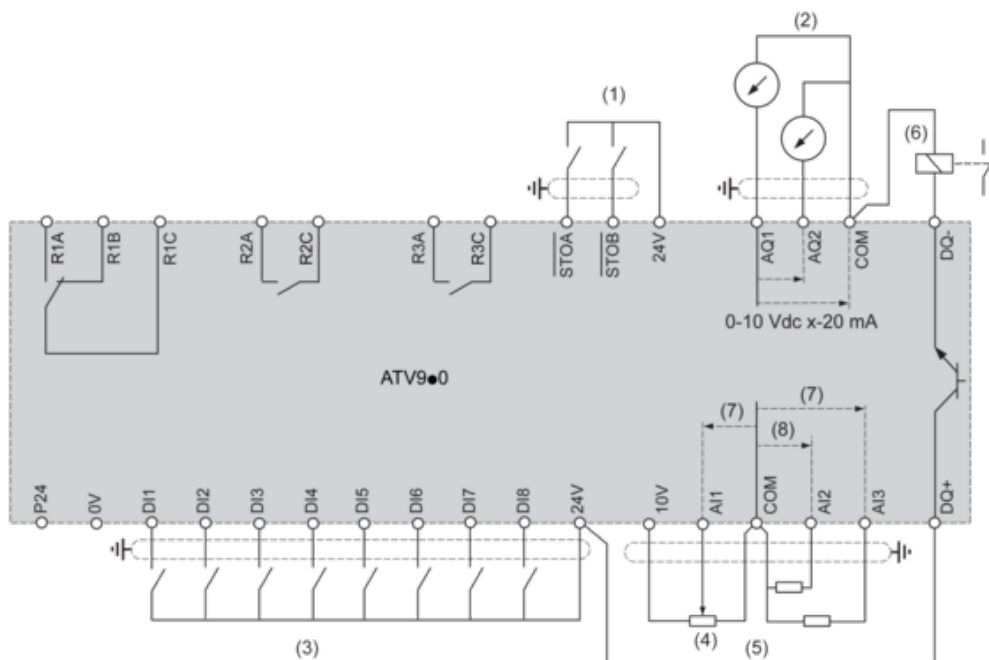

- (1) Safe Torque Off
  - (2) Analog Output
  - (3) Digital Input
  - (4) Reference potentiometer
  - (5) Analog Input
  - (6) Digital Output
  - (7) 0-10 Vdc, x-20 mA
  - (8) 0-10 Vdc, -10 Vdc...+10 Vdc
- R1A, R1B, R1C** : Fault relay  
**R2A, R2C** : Sequence relay  
**R3A, R3C** : Sequence relay

Sensor Connection

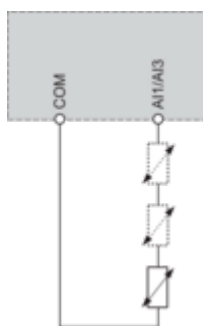

It is possible to connect either 1 or 3 sensors on terminals AI1 or AI3

**Sink / Source Switch Configuration**

The switch is used to adapt the operation of the logic inputs to the technology of the programmable controller outputs.

- Set the switch to Source (factory setting) if using PLC outputs with PNP transistors.
- Set the switch to Ext if using PLC outputs with NPN transistors.

**Switch Set to SRC (Source) Position Using the Output Power Supply for the Digital Inputs**

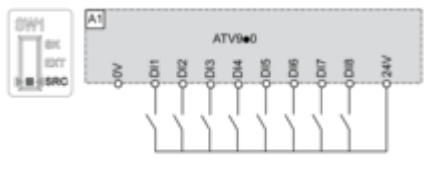

**Switch Set to SRC (Source) Position and Use of an External Power Supply for the DIs**



**Switch Set to SK (Sink) Position Using the Output Power Supply for the Digital Inputs**



**Switch Set to EXT Position Using an External Power Supply for the DIs**

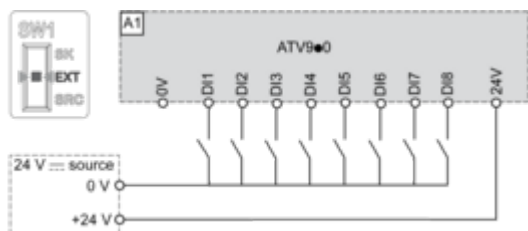

Performance Curves

Derating Curves

---

Normal Duty

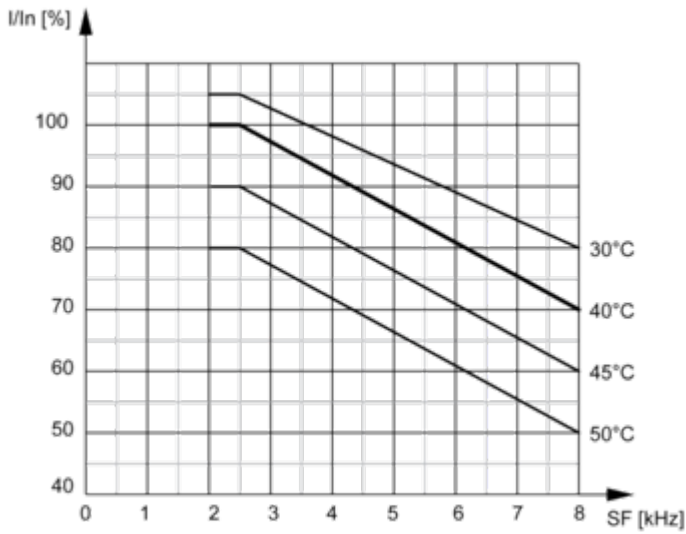

In : Nominal Drive Current  
 SF : Switching Frequency

Heavy Duty

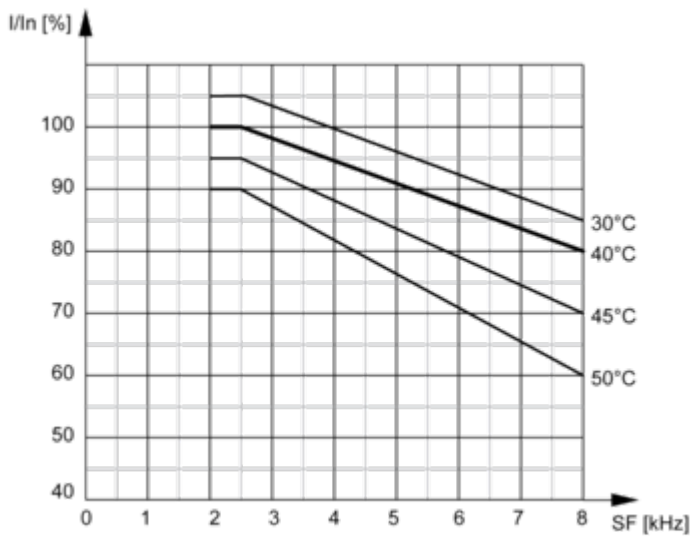

In : Nominal Drive Current  
 SF : Switching Frequency