

Product datasheet

Specifications



Variable speed drive. Altivar Process ATV900. High Performance System ATV960. 560/450 kW. 400 V. IP23

ATV960C56Q4X1

Price: 1,352,208.78 ZAR

Main

| | |
|--|--|
| Device Application | Industrial application |
| Device Short Name | ATV960 |
| Product Destination | Synchronous motors Asynchronous motors |
| Provided Equipment | Enclosure Spacial SF Graphical operating panel in the enclosure door Frequency inverter Main switch Line choke Terminal block main supply Terminal block motor |
| Colour Of Enclosure | Light grey (RAL 7035) |
| Ip Degree Of Protection | IP23 conforming to IEC 61800-5-1 |
| Type Of Cooling | Forced convection |
| Supply Frequency | 50/60 Hz +/- 5 % |
| Network Number Of Phases | 3 phases |
| Output Voltage | <= power supply voltage |
| Permissible Temporary Current Boost | 1.2 x In during 60 s (normal duty) 1.5 x In during 60 s (heavy duty) |
| Speed Drive Output Frequency | 0.1...599 Hz |
| Continuous Output Current | 1020 A at 2.5 kHz for normal duty 830 A at 2.5 kHz for heavy duty |
| Power Dissipation In W | 13950 W, total (normal duty) 10500 W, total (heavy duty) 1500 W, control part (normal duty) 1050 W, control part (heavy duty) |
| Volume Of Cooling Air | 280 m3/h for control 2320 m3/h for power |
| Noise Level | 73 dB conforming to 86/188/EEC - physical agents (noise) directive |
| Prospective Line Isc | 50 kA for 100 ms |
| Motor Recommended Cable Cross Section | 5 x (3 x 150 mm ²) (normal duty) 5 x (3 x 120 mm ²) (heavy duty) 4 x (3 x 150 mm ²) (heavy duty) |
| Height | 2150 mm |
| Depth | 664 mm |

Excluding VAT and subject to change. Please check with your local distributor through "Where to buy"

| | |
|------------------------------------|---|
| Option Module | Slot A: communication module for Profibus DP V1 Slot A: communication module for PROFINET Slot A: communication module for DeviceNet Slot A: communication module for EtherCAT Slot A: communication module for CANopen daisy chain RJ45 Slot A: communication module for CANopen SUB-D 9 Slot A: communication module for CANopen screw terminals Slot A/slot B/slot C: digital and analog I/O extension module Slot A/slot B/slot C: output relay extension module Slot B: 5/12 V digital encoder interface module Slot B: analog encoder interface module Slot B: resolver encoder interface module |
| Safety Function | STO (safe torque off), level SIL 3 for ≤ 100 ms |
| Emc Filter | Integrated conforming to EN/IEC 61800-3, category C3, shielded cable with 50 m Integrated conforming to EN/IEC 61800-3, category C4, unshielded cable with 80 m |
| Range Of Product | Altivar Process ATV900 |
| Product Or Component Type | Variable speed drive |
| Communication Port Protocol | Modbus TCP Modbus serial EtherNet/IP |
| [Us] Rated Supply Voltage | 380...415 V - 10...6 % |
| Motor Power Kw | 560 kW for normal duty 450 kW for heavy duty |

Complementary

| | |
|-----------------------------|--|
| Protection Type | Motor: thermal protection Motor: safe torque off Motor: motor phase break Drive: thermal protection Drive: safe torque off Drive: overheating Drive: overcurrent (between output phases and earth) Drive: overload (output) Drive: short-circuit protection Drive: motor phase break Drive: overvoltage (DC bus) Drive: line supply overvoltage Drive: line supply undervoltage Drive: line supply phase loss Drive: overspeed Drive: break on the control circuit Drive: short-circuit protection with semi-conductor fuse (main supply) Drive: fan monitoring |
| Frequency Resolution | Display unit: 0.1 Hz Analog input: 0.012/50 Hz |
| Connector Type | 2 RJ45 for Ethernet IP/Modbus TCP on the control block 1 RJ45 for Modbus serial on the control block |
| Physical Interface | 2-wire RS 485 for Modbus serial |
| Transmission Frame | RTU for Modbus serial |
| Transmission Rate | 10/100 Mbit/s for Ethernet IP/Modbus TCP 4.8, 9.6, 19.2, 38.4 kbit/s for Modbus serial |
| Exchange Mode | Half duplex, full duplex, autonegotiation Ethernet IP/Modbus TCP |
| Data Format | 8 bits, configurable odd, even or no parity for Modbus serial |
| Type Of Polarization | No impedance for Modbus serial |
| Number Of Addresses | 1...247 for Modbus serial |
| Supply | External supply for digital inputs: 24 V DC (19...30 V), <1.25 mA, protection type: overload and short-circuit protection Internal supply for reference potentiometer (1 to 10 kOhm): 10.5 V DC ± 5 %, <10 mA, protection type: overload and short-circuit protection Internal supply for digital inputs and STO: 24 V DC (21...27 V), <200 mA, protection type: overload and short-circuit protection |

| | |
|---|--|
| Local Signalling | LCD display unit front door operation function, status and configuration |
| Input Compatibility | DI1...DI8: discrete input level 1 PLC conforming to EN/IEC 61131-2 DI7, DI8: pulse input level 1 PLC conforming to IEC 65A-68 STOA, STOB: discrete input level 1 PLC conforming to EN/IEC 61131-2 |
| Discrete Input Logic | Positive logic (source) (DI1...DI8), < 5 V (state 0), > 11 V (state 1) Negative logic (sink) (DI1...DI8), > 16 V (state 0), < 10 V (state 1) Positive logic (source) (DI7, DI8), < 0.6 V (state 0), > 2.5 V (state 1) Positive logic (source) (STOA, STOB), < 5 V (state 0), > 11 V (state 1) |
| Sampling Duration | 2 ms +/- 0.5 ms (DI1...DI8) - discrete input 5 ms +/- 1 ms (DI7, DI8) - pulse input 1 ms +/- 1 ms (AI1, AI2, AI3) - analog input 5 ms +/- 1 ms (AQ1, AQ2) - analog output |
| Accuracy | +/- 0.6 % AI1, AI2, AI3 for a temperature variation 60 °C analog input +/- 1 % AQ1, AQ2 for a temperature variation 60 °C analog output |
| Linearity Error | AI1, AI2, AI3: +/- 0.15 % of maximum value for analog input AQ1, AQ2: +/- 0.2 % for analog output |
| Refresh Time | Relay output (R1, R2, R3): 5 ms (+/- 0.5 ms) |
| Isolation | Between power and control terminals |
| Discrete Input Number | 10 |
| Discrete Input Type | DI1...DI8 programmable, 24 V DC (<= 30 V), impedance: 3.5 kOhm DI7, DI8 programmable as pulse input: 0...30 kHz, 24 V DC (<= 30 V) STOA, STOB safe torque off, 24 V DC (<= 30 V), impedance: > 2.2 kOhm |
| Discrete Input Logic | 16 preset speeds |
| Discrete Output Number | 2 |
| Discrete Output Type | Logic output DQ+ 0...1 kHz <= 30 V DC 100 mA Programmable as pulse output DQ+ 0...30 kHz <= 30 V DC 100 mA Logic output DQ- 0...1 kHz <= 30 V DC 100 mA |
| Analogue Input Number | 3 |
| Analogue Input Type | AI1, AI2, AI3 software-configurable voltage: 0...10 V DC, impedance: 30 kOhm, resolution 12 bits AI1, AI2, AI3 software-configurable current: 0...20 mA, impedance: 250 Ohm, resolution 12 bits |
| Analogue Output Number | 2 |
| Analogue Output Type | Software-configurable voltage AQ1, AQ2: 0...10 V DC impedance 470 Ohm, resolution 10 bits Software-configurable current AQ1, AQ2: 0...20 mA impedance 500 Ohm, resolution 10 bits |
| Relay Output Number | 3 |
| Relay Output Type | Configurable relay logic R1: fault relay NO/NC electrical durability 100000 cycles Configurable relay logic R2: sequence relay NO electrical durability 1000000 cycles Configurable relay logic R3: sequence relay NO electrical durability 1000000 cycles |
| Maximum Switching Current | Relay output R1 on resistive load, cos phi = 1: 3 mA at 250 V AC Relay output R1 on resistive load, cos phi = 1: 3 mA at 30 V DC Relay output R1 on inductive load, cos phi = 0.4 and L/R = 7 ms: 2 mA at 250 V AC Relay output R1 on inductive load, cos phi = 0.4 and L/R = 7 ms: 2 mA at 30 V DC Relay output R2, R3 on resistive load, cos phi = 1: 5 mA at 250 V AC Relay output R2, R3 on resistive load, cos phi = 1: 5 mA at 30 V DC Relay output R2, R3 on inductive load, cos phi = 0.4 and L/R = 7 ms: 2 mA at 250 V AC Relay output R2, R3 on inductive load, cos phi = 0.4 and L/R = 7 ms: 2 mA at 30 V DC |
| Minimum Switching Current | Relay output R1, R2, R3: 5 mA at 24 V DC |
| Method Of Access | Slave Modbus TCP |
| Asynchronous Motor Control Profile | Optimized torque mode Variable torque standard Constant torque standard |
| Synchronous Motor Control Profile | Permanent magnet motor |

| | |
|--|---|
| Acceleration And Deceleration Ramps | S, U or customized Linear adjustable separately from 0.01 to 9000 s |
| Motor Slip Compensation | Automatic whatever the load Not available in permanent magnet motor law Can be suppressed Adjustable |
| Switching Frequency | 2...8 kHz adjustable with derating factor |
| Nominal Switching Frequency | 2.5 kHz |
| Braking To Standstill | By DC injection |
| Line Current | 948 A at 400 V (normal duty) 767 A at 400 V (heavy duty) |
| Apparent Power | 656 kVA at 400 V (normal duty) 531 kVA at 400 V (heavy duty) |
| Maximum Transient Current | 1224 A during 60 s per 10 min (normal duty) 1245 A during 60 s per 10 min (heavy duty) |
| Short-Circuit Protection | Upstream: 1250 A gG fuse (normal duty) Upstream: 1000 A gG fuse (heavy duty) Internal: 400 A 4 aR fuse |
| Electrical Connection | Removable screw terminals, clamping capacity: 0.5...1.5 mm ² for control M12 bar for main supply M12 bar for motor |
| Cable Entry | Bottom |
| Width | 1200 mm |
| Net Weight | 850 kg |

Environment

| | |
|-------------------------------------|--|
| Insulation Resistance | > 1 MOhm 500 V DC for 1 minute to earth |
| Pollution Degree | 2 conforming to EN/IEC 61800-5-1 |
| Vibration Resistance | 1.5 mm peak to peak (f= 3...10 Hz) conforming to IEC 60068-2-6 0.6 gn (f= 10...200 Hz) conforming to IEC 60068-2-6 3M3 conforming to IEC 60721-3-3 |
| Shock Resistance | 4 gn for 11 ms conforming to IEC 60068-2-27 3M2 conforming to IEC 60721-3-3 |
| Relative Humidity | 5...95 % without condensation conforming to IEC 60068-2-3 |
| Operating Altitude | < 1000 m without derating 1000...2000 m with current derating 1 % per 100 m 2000...3800 m with current derating 1 % per 100 m for TT earthing system 2000...3800 m with current derating 1 % per 100 m for TN earthing system 2000...3800 m with current derating 1 % per 100 m for IT earthing system 3800...4800 m with current derating 1 % per 100 m for TT earthing system 3800...4800 m with current derating 1 % per 100 m for TN earthing system |
| Environmental Characteristic | Chemical pollution resistance class 3C3 conforming to EN/IEC 60721-3-3 Dust pollution resistance class 3S3 conforming to EN/IEC 60721-3-3 Humidity resistant class 3K3 conforming to EN/IEC 60721-3-3 |
| Product Certifications | ATEX C-Tick EAC |
| Operating Position | Vertical +/- 10 degree |
| Marking | CE |
| Standards | EN/IEC 60204-1 EN/IEC 61800-5-1 EN/IEC 61800-3 EN/IEC 61800-2 |
| Maximum Thdi | <48 % full load conforming to IEC 61000-3-12 |

| | |
|--|--|
| Assembly Style | In floor-standing enclosure compact version |
| Electromagnetic Compatibility | Electrostatic discharge immunity test level 3 conforming to IEC 61000-4-2 Radiated radio-frequency electromagnetic field immunity test level 3 conforming to IEC 61000-4-3 Electrical fast transient/burst immunity test level 4 conforming to IEC 61000-4-4 1.2/50 μ s - 8/20 μ s surge immunity test level 3 conforming to IEC 61000-4-5 Conducted radio-frequency immunity test level 3 conforming to IEC 61000-4-6 |
| Overvoltage Category | III |
| Ambient Air Temperature For Operation | -10...0 °C without derating (with option enclosure heating) 0...40 °C without derating 40...50 °C with derating factor |
| Ambient Air Temperature For Storage | -25...70 °C |

Packing Units

| | |
|-------------------------------------|---------|
| Unit Type Of Package 1 | PCE |
| Number Of Units In Package 1 | 1 |
| Package 1 Height | 215 cm |
| Package 1 Width | 66.9 cm |
| Package 1 Length | 120 cm |
| Package 1 Weight | 910 kg |
| Unit Type Of Package 2 | CAR |
| Number Of Units In Package 2 | 1 |
| Package 2 Height | 230 cm |
| Package 2 Width | 80 cm |
| Package 2 Length | 135 cm |
| Package 2 Weight | 910 kg |

Sustainability

Green Premium™ label is Schneider Electric's commitment to delivering products with best-in-class environmental performance. Green Premium promises compliance with the latest regulations, transparency on environmental impacts, as well as circular and low-CO₂ products.

Guide to assessing product sustainability is a white paper that clarifies global eco-label standards and how to interpret environmental declarations.

[Learn more about Green Premium >](#)

[Guide to assess a product's sustainability >](#)



Take-back

Resource performance

✓ Take-Back Program Available

Well-being performance

✓ Mercury Free

✓ Rohs Exemption Information Yes

Reach Regulation [REACH Declaration](#)

Eu Rohs Directive Pro-active compliance (Product out of EU RoHS legal scope)

China Rohs Regulation [China RoHS declaration](#)

Weee The product must be disposed on European Union markets following specific waste collection and never end up in rubbish bins

Dimensions Drawings

Dimensions

Right and Front Views

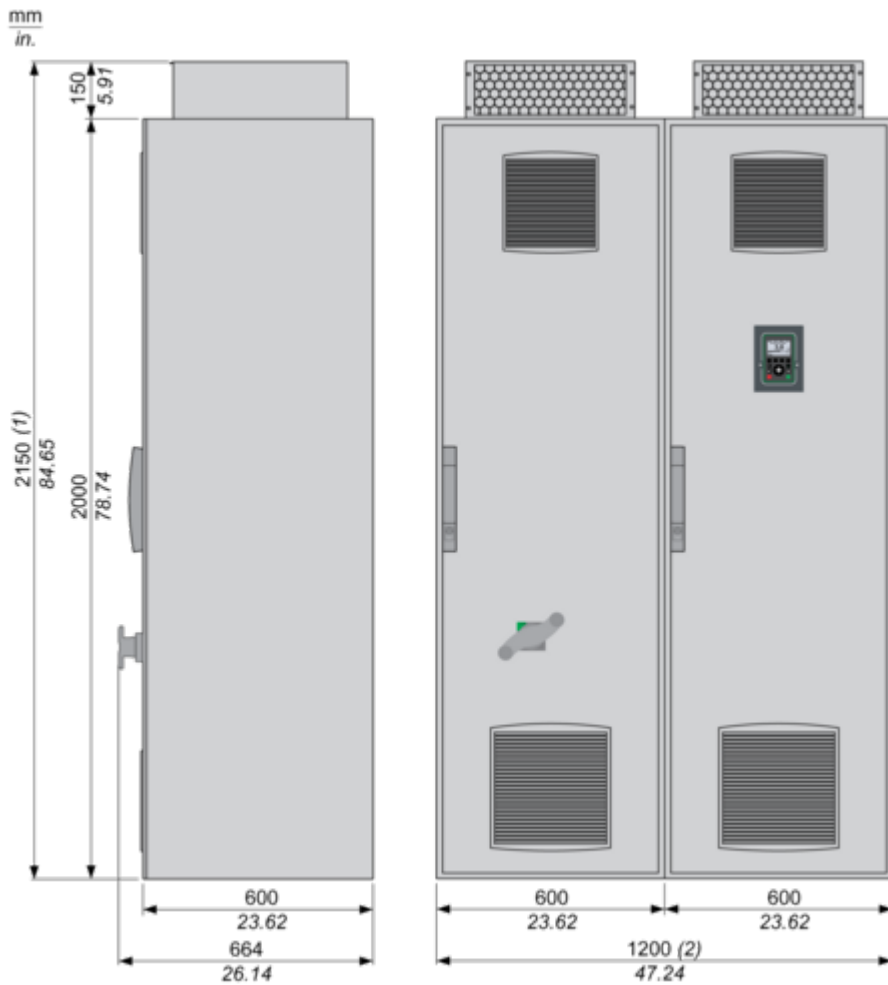

(1) + 200 mm / 7.87 in. with option enclosure plinth or increased protection degree IP54

(2) + 600 mm / 23.62 in. with option connection enclosure cable from top/bottom

Mounting and Clearance

Mounting and Clearance



(1) Air inflow temperature: -10...+50 °C (below 0 °C with option enclosure heating, above +40 °C with derating).

Connections and Schema

Typical Wiring of the Frequency Inverter

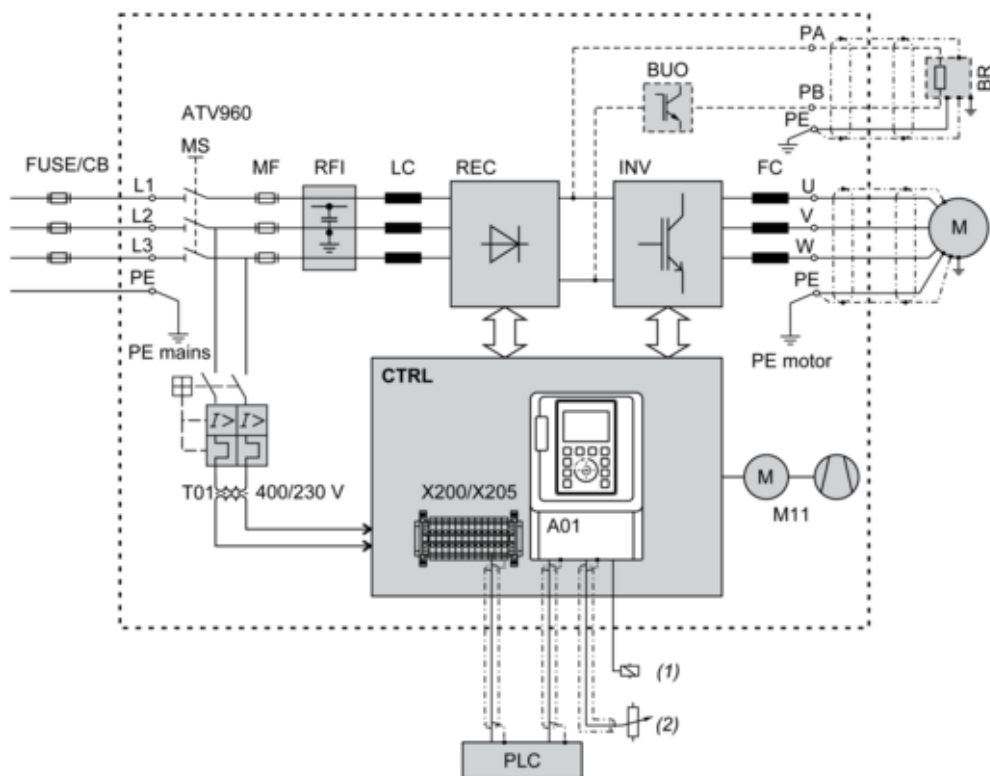

(1) Relay control

(2) Reference value

FUSE/CB External pre-fuse or circuit breaker to protect the main cable

MS Built-in main switch, lockable in open position

T01 Control transformer 400 / 230 V AC

MF aR fuse for short-circuit shut-down if the electronic protective devices do not work properly

Clean Power Filter Clean Power Filter with integrated EMC filter

LC Filter choke

AIC Active Infeed Converter module(s)

INV Inverter module(s)

FC dv/dt filter choke to reduce the voltage load of the motor (at some types a "dv/dt filter choke" is already integrated)

CTRL Control panel with control block and further control components

A01 Control terminals at the control block

X200 / X205 Control terminals at the control panel

M11 Fan in enclosure door

BUO Braking unit option

BR Braking resistor (option)

Structure of the Control Block

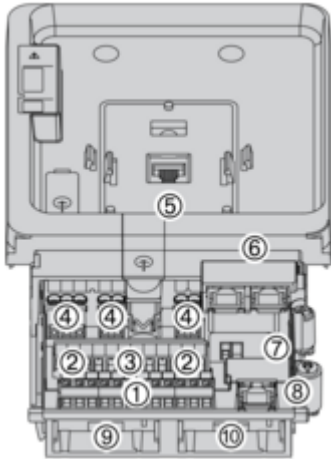

- (1) Control terminals of digital inputs
- (2) Control terminals STO (Safe Torque Off) and analog outputs
- (3) Control terminals of analog inputs
- (4) Control terminals of relay outputs
- (5) RJ45 port for the graphical keypad
- (6) Dual port RJ45 for Ethernet IP or Modbus TCP
- (7) Sink-Ext-Source selector switch and PTO/DQ selector switch
- (8) RJ45 port for serial Modbus
- (9) Slot B for I/O expansion card or encoder interface module
- (10) Slot A for communication card or I/O expansion card

Control Block Wiring Diagram

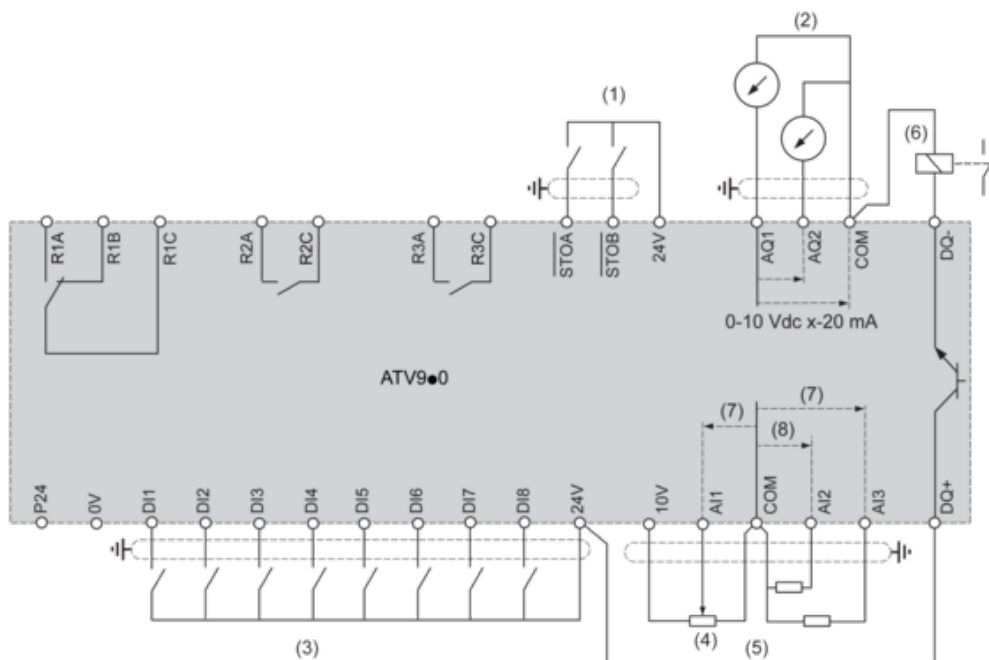

- (1) Safe Torque Off
 - (2) Analog Output
 - (3) Digital Input
 - (4) Reference potentiometer
 - (5) Analog Input
 - (6) Digital Output
 - (7) 0-10 Vdc, x-20 mA
 - (8) 0-10 Vdc, -10 Vdc...+10 Vdc
- R1A, R1B, R1C** : Fault relay
R2A, R2C : Sequence relay
R3A, R3C : Sequence relay

Sensor Connection

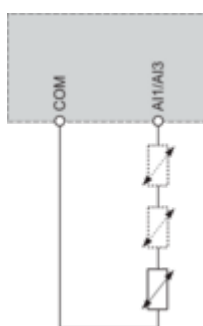

It is possible to connect either 1 or 3 sensors on terminals AI1 or AI3

Sink / Source Switch Configuration

The switch is used to adapt the operation of the logic inputs to the technology of the programmable controller outputs.

- Set the switch to Source (factory setting) if using PLC outputs with PNP transistors.
- Set the switch to Ext if using PLC outputs with NPN transistors.

Switch Set to SRC (Source) Position Using the Output Power Supply for the Digital Inputs

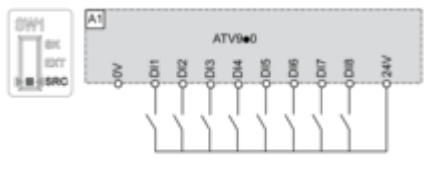

Switch Set to SRC (Source) Position and Use of an External Power Supply for the DIs



Switch Set to SK (Sink) Position Using the Output Power Supply for the Digital Inputs



Switch Set to EXT Position Using an External Power Supply for the DIs

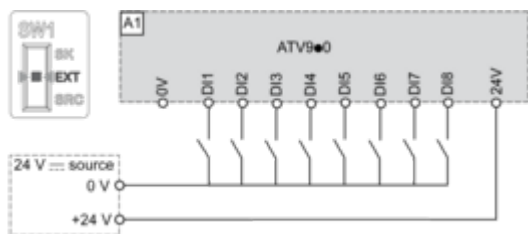

Performance Curves

Derating Curves

Normal Duty

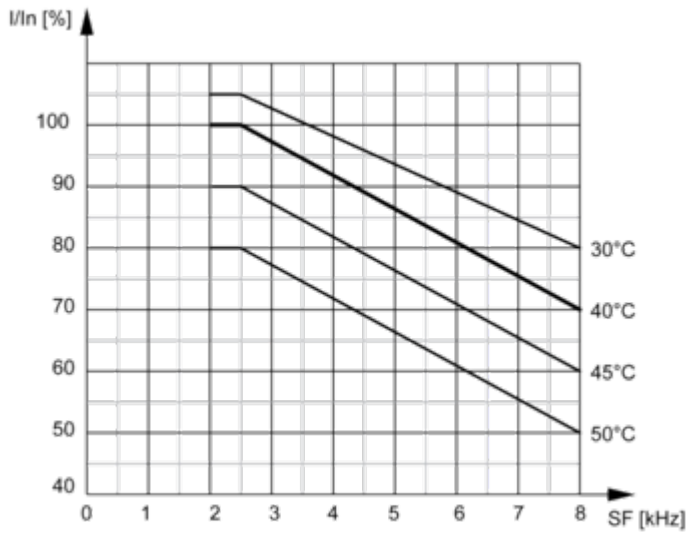

In : Nominal Drive Current
 SF : Switching Frequency

Heavy Duty

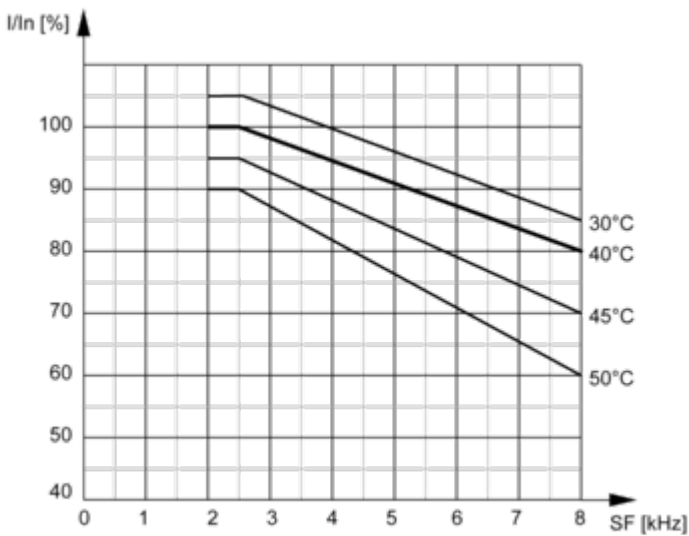

In : Nominal Drive Current
 SF : Switching Frequency