

# Product datasheet

Specifications



## Variable speed drive. Altivar Process ATV900. Regenerative System ATV980 -500/400 kW. 400 V with CE. IP23

ATV980C50Q4X1

**Price: 2,182,354.59 ZAR**

### Main

Device Application	Industrial application
Device Short Name	ATV980
Provided Equipment	Enclosure Spacial SF Graphical operating panel in the enclosure door Frequency inverter Main switch Line choke Terminal block main supply Terminal block motor Dv/dt filter choke
Colour Of Enclosure	Light grey (RAL 7035)
Noise Level	75 dB conforming to 86/188/EEC - physical agents (noise) directive
Type Of Polarization	No impedance for Modbus serial
Supply	External supply for digital inputs: 24 V DC (19...30 V), <1.25 mA, protection type: overload and short-circuit protection Internal supply for digital inputs and STO: 24 V DC (21...27 V), <200 mA, protection type: overload and short-circuit protection Internal supply for reference potentiometer (1 to 10 kOhm): 10.5 V DC +/- 0.5, <10 mA, protection type: overload and short-circuit protection
Range Of Product	Altivar Process ATV900
Product Or Component Type	Variable speed drive
Communication Port Protocol	Modbus serial EtherNet/IP Modbus TCP
[Us] Rated Supply Voltage	380...415 V - 10...6 %
Motor Power Kw	500 kW for normal duty 400 kW for heavy duty

### Complementary

Product Destination	asynchronous motors synchronous motors
Type Of Cooling	Forced convection
Supply Frequency	50...60 Hz +/- 5 %
Network Number Of Phases	3 phases
Output Voltage	<= power supply voltage
Permissible Temporary Current Boost	1.2 x In during 60 s (normal duty) 1.5 x In during 60 s (heavy duty)
Speed Drive Output Frequency	0.1...599 Hz

Excluding VAT and subject to change. Please check with your local distributor through "Where to buy"

<b>Continuous Output Current</b>	900 A at 2.5 kHz for normal duty 730 A at 2.5 kHz for heavy duty
<b>Energy Efficiency Ratio</b>	0.965
<b>Power Dissipation In W</b>	20800 W, total (normal duty) 15830 W, total (heavy duty) 2400 W, control part (normal duty) 1780 W, control part (heavy duty)
<b>Volume Of Cooling Air</b>	3480 m3/h for power 420 m3/h for control
<b>Prospective Line Isc</b>	50 kA for 100 ms
<b>Motor Recommended Cable Cross Section</b>	5 x (3 x 120 mm <sup>2</sup> ) (normal duty) 4 x (3 x 185 mm <sup>2</sup> ) (normal duty) 3 x (3 x 185 mm <sup>2</sup> ) (heavy duty) 4 x (3 x 120 mm <sup>2</sup> ) (heavy duty)
<b>Height</b>	2150 mm
<b>Depth</b>	664 mm
<b>Option Module</b>	Slot A: communication module for EtherCAT Slot A/slot B/slot C: digital and analog I/O extension module Slot A/slot B/slot C: output relay extension module Slot A: communication module for CANopen daisy chain RJ45 Slot A: communication module for CANopen screw terminals Slot A: communication module for CANopen SUB-D 9 Slot A: communication module for DeviceNet Slot A: communication module for Profibus DP V1 Slot A: communication module for PROFINET Slot B: 512 V digital encoder interface module Slot B: resolver encoder interface module Slot B: digital encoder interface module Slot B: analog encoder interface module
<b>Safety Function</b>	STO (safe torque off), level SIL 3 for <= 100 ms
<b>Protection Type</b>	Motor: thermal protection Motor: safe torque off Motor: motor phase break Drive: thermal protection Drive: safe torque off Drive: overheating Drive: overcurrent (between output phases and earth) Drive: overload (output) Drive: short-circuit protection Drive: motor phase break Drive: overvoltage (DC bus) Drive: line supply overvoltage Drive: line supply undervoltage Drive: line supply phase loss Drive: overspeed Drive: break on the control circuit Drive: short-circuit protection with semi-conductor fuse (main supply) Drive: fan monitoring
<b>Frequency Resolution</b>	Display unit: 0.1 Hz Analog input: 0.012/50 Hz
<b>Connector Type</b>	2 RJ45 for Ethernet IP/Modbus TCP on the control block 1 RJ45 for Modbus serial on the control block
<b>Physical Interface</b>	2-wire RS 485 for Modbus serial
<b>Transmission Frame</b>	RTU for Modbus serial
<b>Transmission Rate</b>	10/100 Mbit/s for Ethernet IP/Modbus TCP 4.8, 9.6, 19.2, 38.4 kbit/s for Modbus serial
<b>Exchange Mode</b>	Half duplex, full duplex, autonegotiation Ethernet IP/Modbus TCP
<b>Data Format</b>	8 bits, configurable odd, even or no parity for Modbus serial
<b>Number Of Addresses</b>	1...247 for Modbus serial
<b>Local Signalling</b>	LCD display unit front door operation function, status and configuration

<b>Input Compatibility</b>	DI1...DI8: discrete input level 1 PLC conforming to EN/IEC 61131-2 DI7, DI8: pulse input level 1 PLC conforming to IEC 65A-68 STOA, STOB: discrete input level 1 PLC conforming to EN/IEC 61131-2
<b>Discrete Input Logic</b>	Positive logic (source) (DI1...DI8), < 5 V (state 0), > 11 V (state 1) Negative logic (sink) (DI1...DI8), > 16 V (state 0), < 10 V (state 1) Positive logic (source) (DI7, DI8), < 0.6 V (state 0), > 2.5 V (state 1) Positive logic (source) (STOA, STOB), < 5 V (state 0), > 11 V (state 1)
<b>Sampling Duration</b>	2 ms +/- 0.5 ms (DI1...DI8) - discrete input 5 ms +/- 1 ms (DI7, DI8) - pulse input 1 ms +/- 1 ms (AI1, AI2, AI3) - analog input 5 ms +/- 1 ms (AQ1, AQ2) - analog output
<b>Accuracy</b>	+/- 0.6 % AI1, AI2, AI3 for a temperature variation 60 °C analog input +/- 1 % AQ1, AQ2 for a temperature variation 60 °C analog output
<b>Linearity Error</b>	AI1, AI2, AI3: +/- 0.15 % of maximum value for analog input AQ1, AQ2: +/- 0.2 % for analog output
<b>Refresh Time</b>	Relay output (R1, R2, R3): 5 ms (+/- 0.5 ms)
<b>Isolation</b>	Between power and control terminals
<b>Insulation Resistance</b>	> 1 MOhm 500 V DC for 1 minute to earth
<b>Discrete Input Number</b>	10
<b>Discrete Input Type</b>	DI1...DI8 programmable, 24 V DC (30 V), impedance: 3.5 kOhm DI7, DI8 programmable as pulse input: 0...30 kHz, 24 V DC STOA, STOB safe torque off, 24 V DC, impedance: > 2.2 kOhm
<b>Discrete Input Logic</b>	16 preset speeds
<b>Discrete Output Number</b>	2
<b>Discrete Output Type</b>	Logic output DQ+ 0...1 kHz <= 30 V DC 100.0 mA Programmable as pulse output DQ+ 0...30 kHz <= 30 V DC 20.0 mA Logic output DQ- 0...1 kHz <= 30 V DC 100.0 mA
<b>Analogue Input Number</b>	3
<b>Analogue Input Type</b>	AI1, AI2, AI3 software-configurable voltage: 0...10 V DC, impedance: 30 kOhm, resolution 12 bits AI1, AI2, AI3 software-configurable current: 0...20 mA, impedance: 250 Ohm, resolution 12 bits
<b>Analogue Output Number</b>	2
<b>Analogue Output Type</b>	Software-configurable voltage AQ1, AQ2: 0...10 V DC impedance 470 Ohm, resolution 10 bits Software-configurable current AQ1, AQ2: 0...20 mA impedance 500 Ohm, resolution 10 bits
<b>Relay Output Number</b>	3
<b>Relay Output Type</b>	Configurable relay logic R1: fault relay NO/NC electrical durability 100000 cycles Configurable relay logic R2: sequence relay NO electrical durability 1000000 cycles Configurable relay logic R3: sequence relay NO electrical durability 1000000 cycles
<b>Maximum Switching Current</b>	Relay output R1 on resistive load, cos phi = 1: 3 A at 250 V AC Relay output R1 on resistive load, cos phi = 1: 3 A at 30 V DC Relay output R1 on inductive load, cos phi = 0.4 and L/R = 7 ms: 2 A at 250 V AC Relay output R1 on inductive load, cos phi = 0.4 and L/R = 7 ms: 2 A at 30 V DC Relay output R2, R3 on resistive load, cos phi = 1: 5 A at 250 V AC Relay output R2, R3 on resistive load, cos phi = 1: 5 A at 30 V DC Relay output R2, R3 on inductive load, cos phi = 0.4 and L/R = 7 ms: 2 A at 250 V AC Relay output R2, R3 on inductive load, cos phi = 0.4 and L/R = 7 ms: 2 A at 30 V DC
<b>Minimum Switching Current</b>	Relay output R1, R2, R3: 5 mA at 24 V DC
<b>Method Of Access</b>	Slave Modbus TCP
<b>Asynchronous Motor Control Profile</b>	Optimized torque mode Constant torque standard Variable torque standard
<b>Synchronous Motor Control Profile</b>	Permanent magnet motor

<b>Acceleration And Deceleration Ramps</b>	S, U or customized Linear adjustable separately from 0.01 to 9000 s
<b>Motor Slip Compensation</b>	Not available in permanent magnet motor law Adjustable Automatic whatever the load Can be suppressed
<b>Switching Frequency</b>	2...8 kHz adjustable with derating factor
<b>Nominal Switching Frequency</b>	2.5 kHz
<b>Braking To Standstill</b>	By DC injection
<b>Line Current</b>	775 A at 400 V (normal duty) 620 A at 400 V (heavy duty)
<b>Apparent Power</b>	537 kVA at 400 V (normal duty) 429 kVA at 400 V (heavy duty)
<b>Maximum Transient Current</b>	1080 A during 60 s per 10 min (normal duty) 1095 A during 60 s per 10 min (heavy duty)
<b>Short-Circuit Protection</b>	Upstream: 1000 A gG fuse (normal duty) Upstream: 800 A gG fuse (heavy duty) Internal: 400 A 3 aR fuse
<b>Electrical Connection</b>	Removable screw terminals, clamping capacity: 0.5...1.5 mm <sup>2</sup> for control M12 bar for main supply M12 bar for motor
<b>Cable Entry</b>	Bottom
<b>Width</b>	1600 mm
<b>Net Weight</b>	1150 kg

## Environment

<b>Ip Degree Of Protection</b>	IP23 conforming to IEC 61800-5-1
<b>Emc Filter</b>	Integrated conforming to EN/IEC 61800-3, category C4, unshielded cable with 250 m
<b>Pollution Degree</b>	2 conforming to EN/IEC 61800-5-1
<b>Vibration Resistance</b>	1.5 mm peak to peak (f= 3...20 Hz) conforming to IEC 60068-2-6 0.6 gn (f= 10...200 Hz) conforming to IEC 60068-2-6 3M3 conforming to IEC 60721-3-3 1.5 mm peak to peak (f= 3...10 Hz) conforming to IEC 60068-2-6
<b>Shock Resistance</b>	4 gn for 11 ms conforming to IEC 60068-2-27 3M2 conforming to IEC 60721-3-3
<b>Relative Humidity</b>	5...95 % without condensation conforming to IEC 60068-2-3
<b>Operating Altitude</b>	<= 1000 m without derating 1000...2000 m with current derating 1 % per 100 m 2000...3800 m with current derating 1 % per 100 m for TT earthing system 2000...3800 m with current derating 1 % per 100 m for TN earthing system 2000...3800 m with current derating 1 % per 100 m for IT earthing system 3800...4800 m with current derating 1 % per 100 m for TT earthing system 3800...4800 m with current derating 1 % per 100 m for TN earthing system
<b>Environmental Characteristic</b>	Chemical pollution resistance class 3C3 conforming to EN/IEC 60721-3-3 Dust pollution resistance class 3S3 conforming to EN/IEC 60721-3-3 Humidity resistant class 3K3 conforming to EN/IEC 60721-3-3
<b>Product Certifications</b>	ATEX C-Tick EAC
<b>Operating Position</b>	Vertical +/- 10 degree
<b>Marking</b>	CE
<b>Standards</b>	EN/IEC 61800-2 EN/IEC 61800-3 EN/IEC 61800-5-1 EN/IEC 60204-1

<b>Maximum Thdi</b>	<5 % full load conforming to IEEE 519
<b>Assembly Style</b>	In floor-standing enclosure compact version
<b>Electromagnetic Compatibility</b>	Electrostatic discharge immunity test level 3 conforming to IEC 61000-4-2 Radiated radio-frequency electromagnetic field immunity test level 3 conforming to IEC 61000-4-3 Electrical fast transient/burst immunity test level 4 conforming to IEC 61000-4-4 1.2/50 $\mu$ s - 8/20 $\mu$ s surge immunity test level 3 conforming to IEC 61000-4-5 Conducted radio-frequency immunity test level 3 conforming to IEC 61000-4-6
<b>Overvoltage Category</b>	III
<b>Ambient Air Temperature For Operation</b>	-10...0 °C without derating (with option enclosure heating) 0...40 °C without derating 40...50 °C with derating factor
<b>Ambient Air Temperature For Storage</b>	-25...70 °C

## Packing Units

<b>Unit Type Of Package 1</b>	PCE
<b>Number Of Units In Package 1</b>	1
<b>Package 1 Height</b>	215 cm
<b>Package 1 Width</b>	66.9 cm
<b>Package 1 Length</b>	160 cm
<b>Package 1 Weight</b>	1220 kg

## Sustainability

**Green Premium™ label** is Schneider Electric's commitment to delivering products with best-in-class environmental performance. Green Premium promises compliance with the latest regulations, transparency on environmental impacts, as well as circular and low-CO<sub>2</sub> products.

**Guide to assessing product sustainability** is a white paper that clarifies global eco-label standards and how to interpret environmental declarations.

[Learn more about Green Premium >](#)

[Guide to assess a product's sustainability >](#)



Take-back

## Resource performance

✓ Take-Back Program Available

---

## Well-being performance

✓ Mercury Free

---

✓ Rohs Exemption Information Yes

---

Reach Regulation [REACH Declaration](#)

---

Eu Rohs Directive Pro-active compliance (Product out of EU RoHS legal scope)

---

China Rohs Regulation [China RoHS declaration](#)

---

Weee The product must be disposed on European Union markets following specific waste collection and never end up in rubbish bins

---

Dimensions Drawings

Dimensions

Right and Front Views

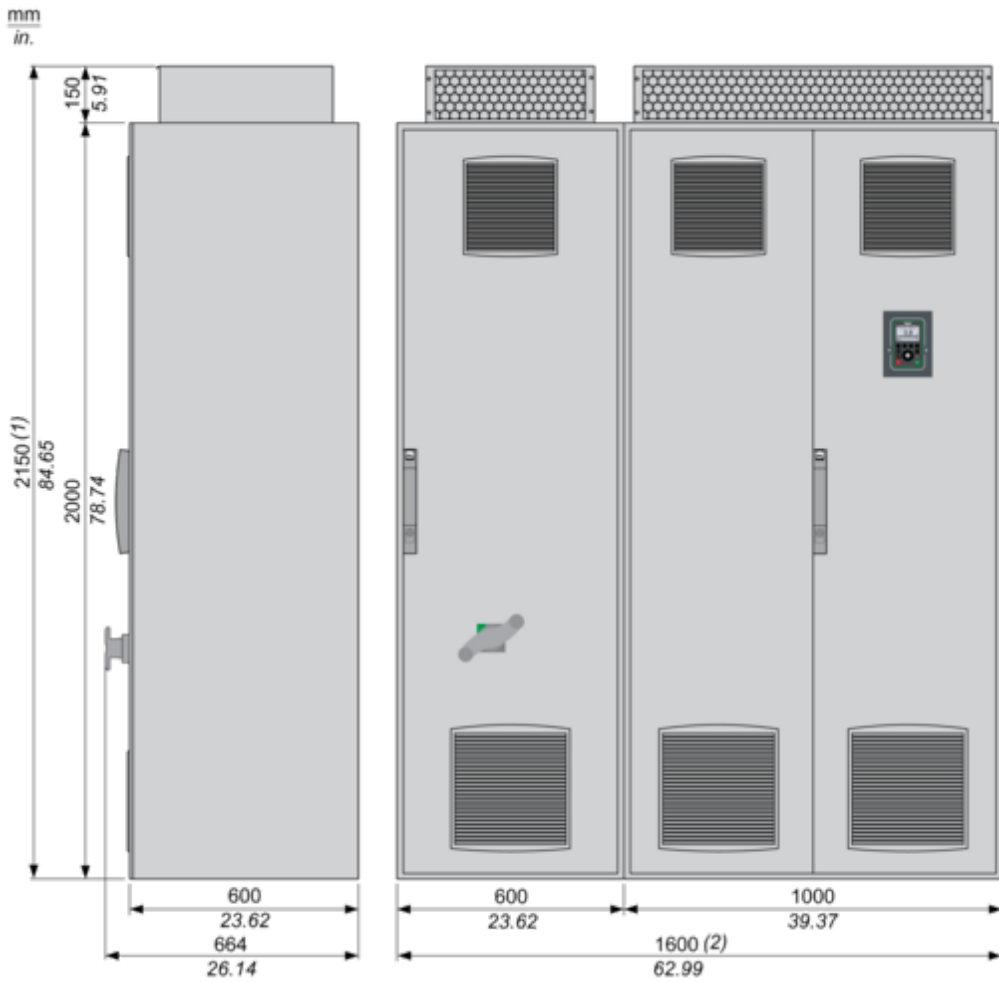

- (1) + 200 mm/7.87 in. with option enclosure plinth or increased protection degree IP54.
- (2) + 600 mm/15.74 in. with option connection enclosure cable from top/bottom.

Mounting and Clearance

Mounting and Clearance

---

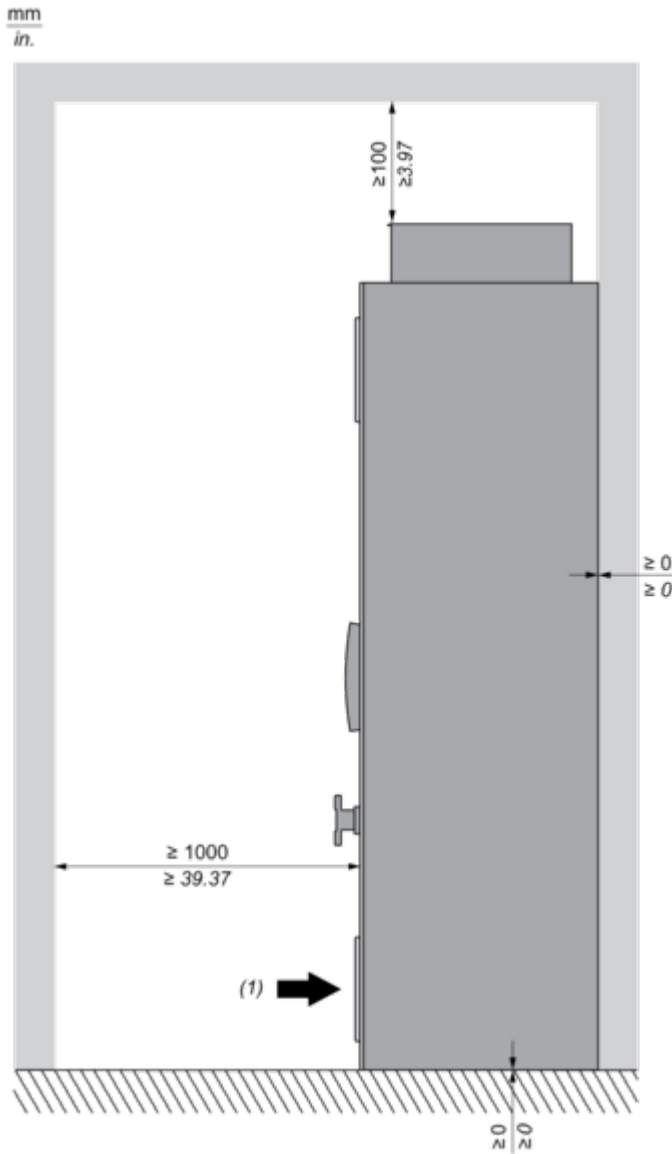

Connections and Schema

Typical Wiring Diagram of the Frequency Inverter

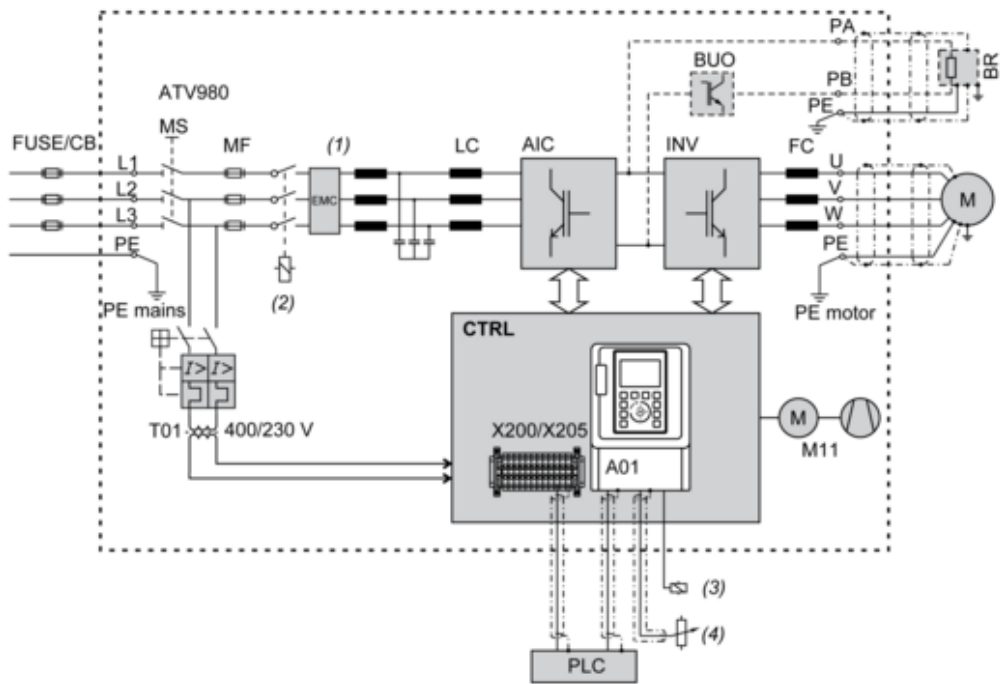

- (1) Clean Power Filter
- (2) Line contactor
- (3) Relay control
- (4) Reference value

**FUSE/CB** External pre-fuse or circuit breaker to protect the main cable

**MS** Built-in main switch, lockable in open position

**T01** Control transformer 400 / 230 V AC

**MF** aR fuse for short-circuit shut-down if the electronic protective devices do not work properly

**Clean Power Filter** Clean Power Filter with integrated EMC filter

**LC** Filter choke

**AIC** Active Infeed Converter module(s)

**INV** Inverter module(s)

**FC** dv/dt filter choke to reduce the voltage load of the motor (at some types a "dv/dt filter choke" is already integrated)

**CTRL** Control panel with control block and further control components

**A01** Control terminals at the control block

**X200 / X205** Control terminals at the control panel

**M11** Fan in enclosure door

**BUO** Braking unit option

**BR** Braking resistor (option)

### Structure of the Control Block

---

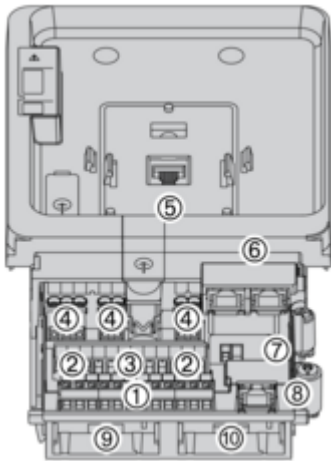

- (1) Control terminals of digital inputs
- (2) Control terminals STO (Safe Torque Off) and analog outputs
- (3) Control terminals of analog inputs
- (4) Control terminals of relay outputs
- (5) RJ45 port for the graphical keypad
- (6) Dual port RJ45 for Ethernet IP or Modbus TCP
- (7) Sink-Ext-Source selector switch and PTO/DQ selector switch
- (8) RJ45 port for serial Modbus
- (9) Slot B for I/O expansion card or encoder interface module
- (10) Slot A for communication card or I/O expansion card

Control Block Wiring Diagram

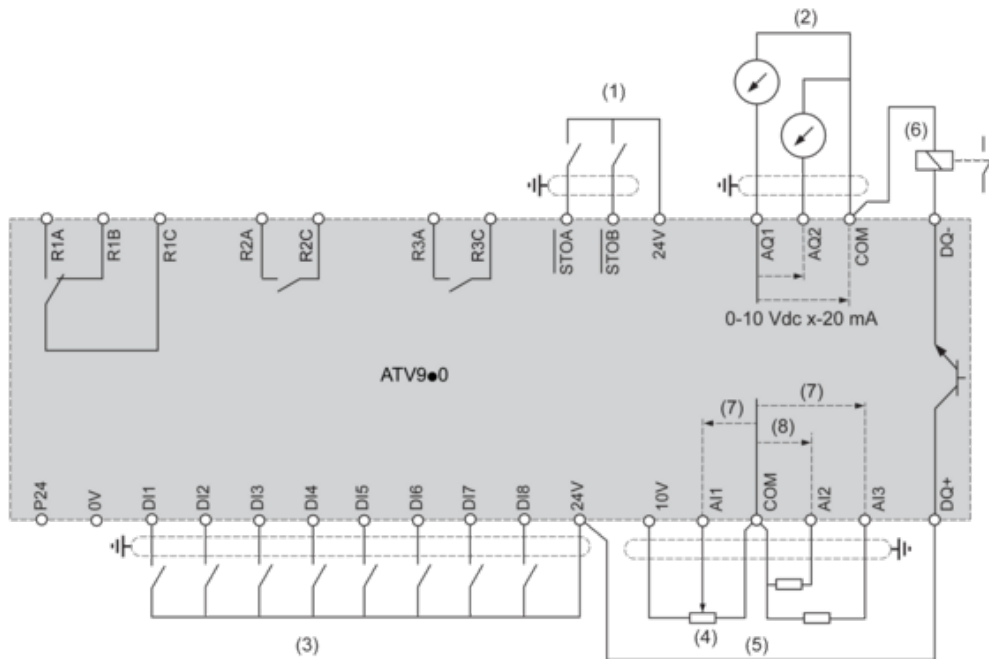

- (1) Safe Torque Off
  - (2) Analog Output
  - (3) Digital Input
  - (4) Reference potentiometer
  - (5) Analog Input
  - (6) Digital Output
  - (7) 0-10 Vdc, x-20 mA
  - (8) 0-10 Vdc, -10 Vdc...+10 Vdc
- R1A, R1B, R1C** : Fault relay  
**R2A, R2C** : Sequence relay  
**R3A, R3C** : Sequence relay

Sensor Connection

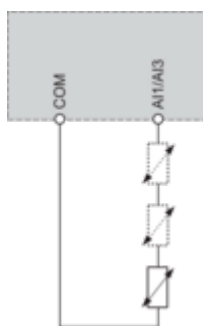

It is possible to connect either 1 or 3 sensors on terminals AI1 or AI3

**Sink / Source Switch Configuration**

The switch is used to adapt the operation of the logic inputs to the technology of the programmable controller outputs.

- Set the switch to Source (factory setting) if using PLC outputs with PNP transistors.
- Set the switch to Ext if using PLC outputs with NPN transistors.

**Switch Set to SRC (Source) Position Using the Output Power Supply for the Digital Inputs**

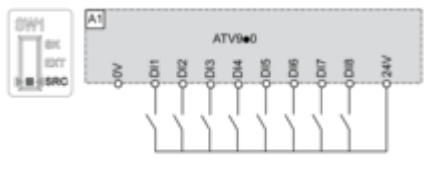

**Switch Set to SRC (Source) Position and Use of an External Power Supply for the DIs**



**Switch Set to SK (Sink) Position Using the Output Power Supply for the Digital Inputs**



**Switch Set to EXT Position Using an External Power Supply for the DIs**

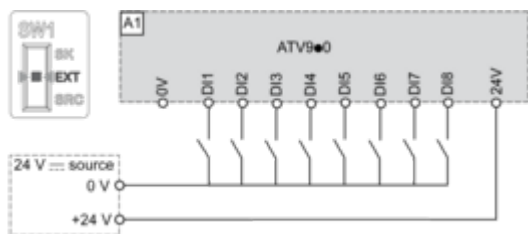

Performance Curves

Derating Curves

---

Normal Duty

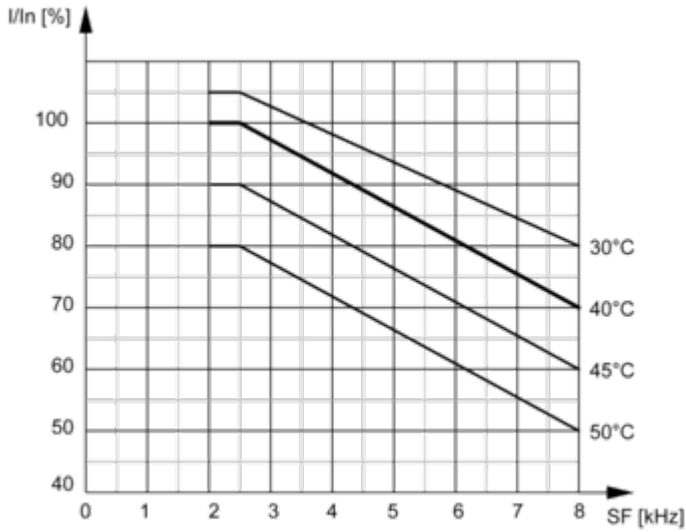

In : Nominal Drive Current  
SF : Switching Frequency

Heavy Duty

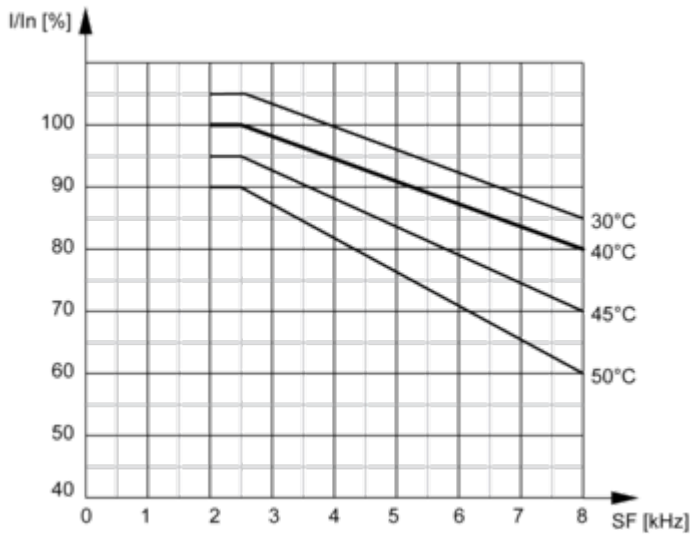

In : Nominal Drive Current  
SF : Switching Frequency