

Data sheet

Commercial Art.No.: 05.587.3156.0

lock (G)ST18 WS

Locking device for cable to cable connection GST18i3-5, white



Commercial Art.No.	05.587.3156.0
EAN	4015573092440
Order Unit	1

Technical data

technical data

length	36.5 mm
width	13.2 mm
height	16.1 mm
color	white
description 1	interlock
description 2	for flying leads

classification

ECLASS 11	
ETIM 9.0	EC002863
ETIM 8.0	EC002863
ETIM 7.0	EC002863
ETIM 6.0	EC002863
ETIM 5.0	EC002863

product compliance

ROHS conformity status	compliant
REACH-SVHC conformity status	compliant

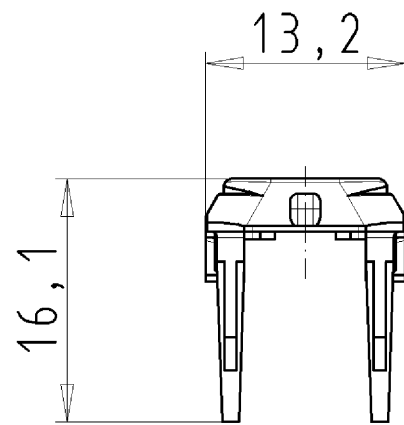
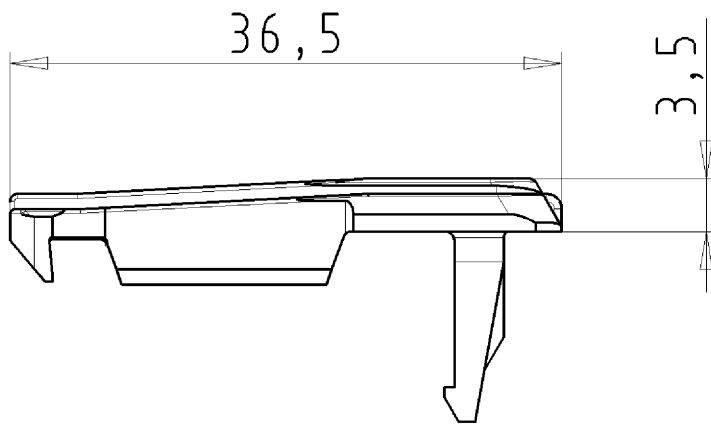

VERRIEGELUNG

05.587.3156.1 10W

03.02.2009 LUS

M 2:1